

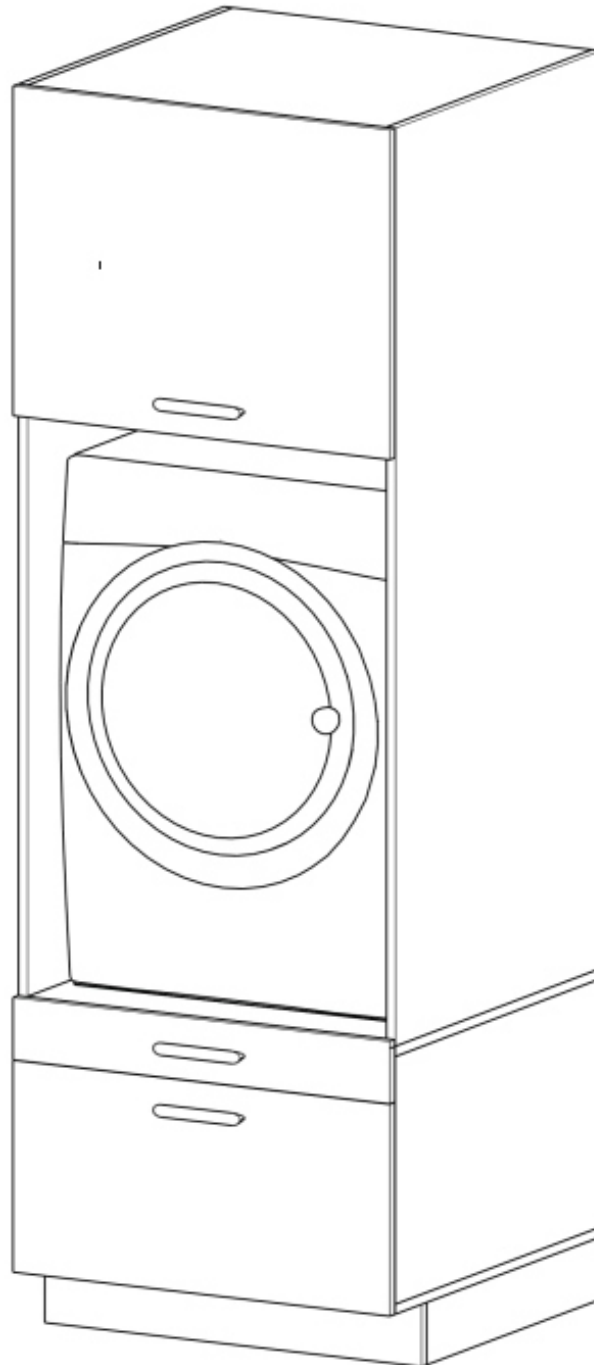

PRALNIA HOLV CZ2

SZAFA | WARDROBE | KLEIDERSCHRANK | ARMARIO | KLEDINGKAST | GUARDAROBA | ARMOIRE ŠATNÍ SKŘÍŇ



+Selsley
design



- Zalecamy nie wyrzucać opakowania dopóki nie ukończysz montażu.
- Montażu najlepiej dokonać na miękkiej i czystej powierzchni, takiej jak tektura, ręcznik, koc.
- Uchroni to przed uszkodzeniem krawędzi mebla.
- Zarówno opakowania plastikowe, jak i okucia trzymaj w miejscu niedostępnym dla niemowląt i dzieci.
- Wszystkie połączenia powinny być odpowiednio dokręcone.
- Przed przystąpieniem do montażu prosimy zapoznać się z całą instrukcją montażu.
- Nie montować elementów, jeśli zauważysz wady lub uszkodzenia.

PRZED PRZYSTĄPIENIEM DO MONTAŻU SPRAWDŹ, CZY NIE BRAKUJE ŻADNYCH ELEMENTÓW.



- We recommend not discarding the packaging until assembly is complete.
- Perform assembly on a soft and clean surface, such as cardboard, a towel, or a blanket.
- This will prevent damage to the edges of the furniture.
- Keep both plastic packaging and hardware out of reach of infants and children.
- Ensure all connections are properly tightened.
- Please read the entire assembly manual before starting assembly.
- Do not assemble parts if you notice defects or damage.

BEFORE STARTING THE ASSEMBLY, CHECK IF ANY PARTS ARE MISSING.



- Wir empfehlen, die Verpackung nicht zu entsorgen, bevor die Montage abgeschlossen ist.
- Führen Sie die Montage auf einer weichen und sauberen Oberfläche wie Pappe, einem Handtuch oder einer Decke durch.
- Dies verhindert Schäden an den Kanten des Möbelstücks.
- Bewahren Sie sowohl die Plastikverpackungen als auch die Beschläge außerhalb der Reichweite von Säuglingen und Kindern auf.
- Stellen Sie sicher, dass alle Verbindungen festgezogen sind.
- Bitte lesen Sie die gesamte Montageanleitung, bevor Sie mit der Montage beginnen.
- Montieren Sie keine Teile, wenn Sie Mängel oder Schäden feststellen.

ÜBERPRÜFEN SIE VOR BEGINN DER MONTAGE, OB TEILE FEHLEN.



- Recomendamos no desechar el embalaje hasta completar el montaje.
- Realice el montaje en una superficie suave y limpia, como cartón, una toalla o una manta.
- Esto evitará daños en los bordes del mueble.
- Mantenga tanto los embalajes de plástico como las piezas fuera del alcance de bebés y niños.
- Asegúrese de que todas las conexiones estén correctamente apretadas.
- Lea todo el manual de montaje antes de comenzar.
- No monte las piezas si nota defectos o daños.

ANTES DE COMENZAR EL MONTAJE, VERIFICA SI FALTA ALGUNA PIEZA.

Kraj pochodzenia: Polska
Country of origin: Poland

Herkunftsland: Polen
País de origen: Polonia

**PRODUCENT | HERSTELLER | FABRIKANT | FABRICANT
MANUFACTURER | FABRICANTE | PRODUTTORE | VÝROBCE:**

„KAROL MEBLE“ DUO Sp. z o.o.
Nowa Wieś Książęca 38
63-640 Bralin



- Wij raden aan de verpakking niet weg te gooien totdat de montage is voltooid.
- Voer de montage uit op een zachte en schone ondergrond, zoals karton, een handdoek of een deken.
- Dit voorkomt beschadiging van de randen van het meubel.
- Houd zowel plastic verpakkingen als beslag buiten het bereik van baby's en kinderen.
- Zorg ervoor dat alle verbindingen goed zijn aangedraaid.
- Lees de volledige montagehandleiding voordat u begint.
- Monteer geen onderdelen als u gebreken of schade opmerkt.

CONTROLEER VÓÓR DE MONTAGE OF ER ONDERDELEN ONTBREKEN.



- Si consiglia di non gettare l'imballaggio fino al completamento del montaggio.
- Eseguire il montaggio su una superficie morbida e pulita, come cartone, asciugamano o coperta.
- Questo proteggerà i bordi del mobile da eventuali danni.
- Tenere sia gli imballaggi in plastica che la ferramenta fuori dalla portata di neonati e bambini.
- Assicurarsi che tutte le connessioni siano adeguatamente serrate.
- Si prega di leggere attentamente l'intero manuale di montaggio prima di iniziare.
- Non montare i componenti se si notano difetti o danni.

PRIMA DI PROCEDERE CON IL MONTAGGIO, VERIFICA SE MANCANO DEI PEZZI.



- Nous recommandons de ne pas jeter l'emballage avant d'avoir terminé le montage.
- Assemblez sur une surface douce et propre, comme du carton, une serviette ou une couverture.
- Cela évitera d'endommager les bords du meuble.
- Gardez les emballages en plastique et les fixations hors de portée des nourrissons et des enfants.
- Assurez-vous que toutes les connexions sont correctement serrées.
- Veuillez lire l'intégralité du manuel d'assemblage avant de commencer.
- Ne montez pas les éléments si vous constatez des défauts ou des dommages.

AVANT DE COMMENCER LE MONTAGE, VÉRIFIEZ S'IL MANQUE DES PIÈCES.



- Doporučujeme nevyhazovat obal, dokud nedokončíte montáž.
- Montáž provádějte na měkkém a čistém povrchu, jako je karton, ručník nebo deka.
- To zabrání poškození hran nábytku.
- Uchovávejte plastové obaly i kování mimo dosah kojenců a dětí.
- Ujistěte se, že všechny spoje jsou řádně utaženy.
- Před zahájením montáže si prosím přečtěte celý montážní návod.
- Nemontujte díly, pokud zjistíte vady nebo poškození.

PŘED ZAHÁJENÍM MONTÁŽE ZKONTROLUJTE, ZDA NECHYBÍ ŽÁDNÉ DÍLY.

Land van herkomst: Polen
Paese di origine: Polonia

Pays d'origine: Pologne
Země původu: Polsko

**DYSTRYBUTOR | VERTRIEBSPARTNER | DISTRIBUTEUR | DISTRIBUTEUR
DISTRIBUTOR | DISTRIBUIDOR | DISTRIBUTORE | DISTRIBUTOR**

SELSEY Sp. z o.o.
ul. Fabryczna 6
63-609 Wrocław
biuro@selsey.pl

PRALNIA HOLV CZ2

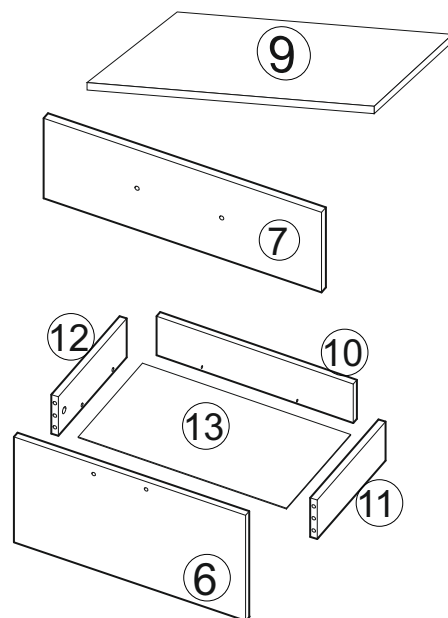
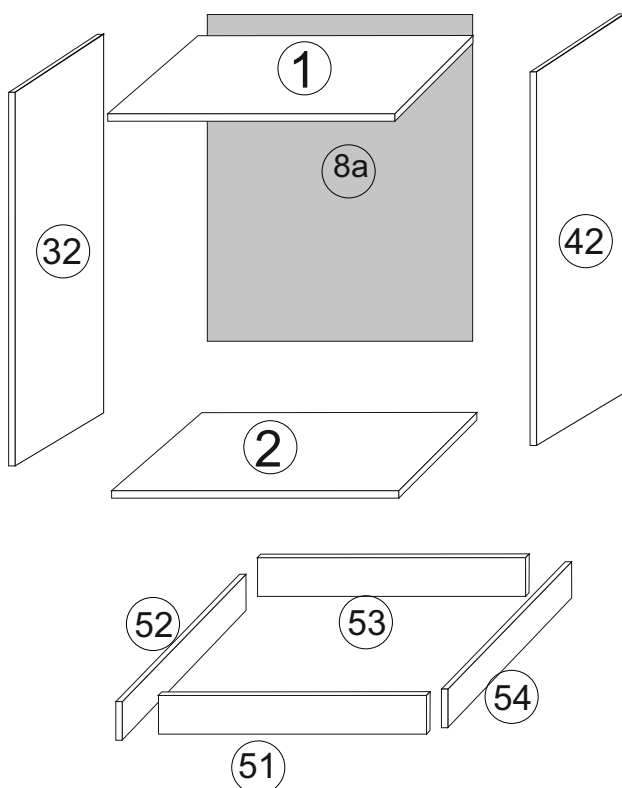
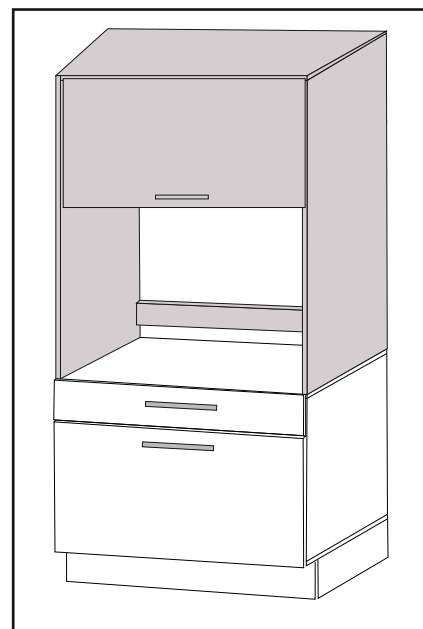
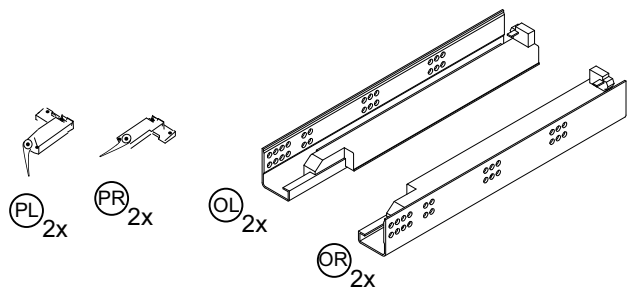
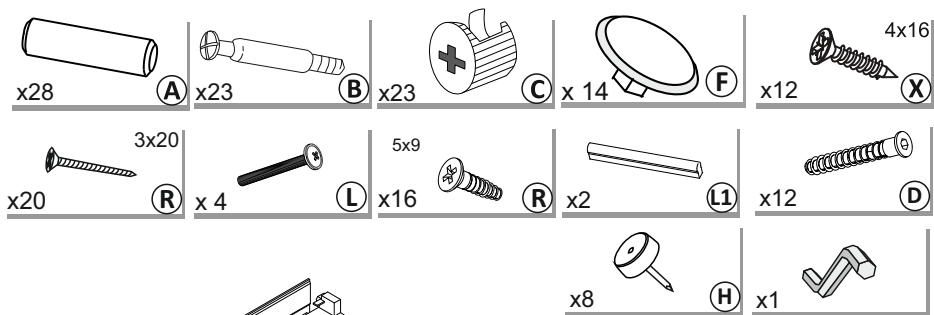

+S

1

PRALNIA HOLV CZ2

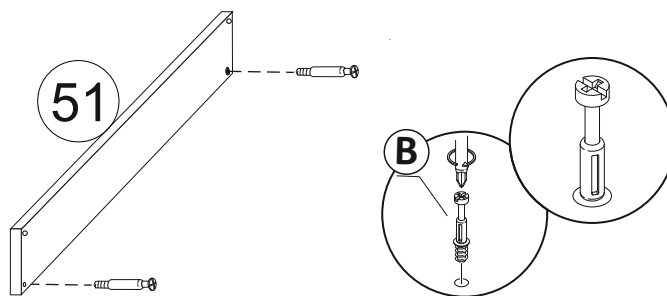
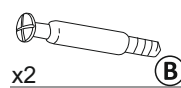

2

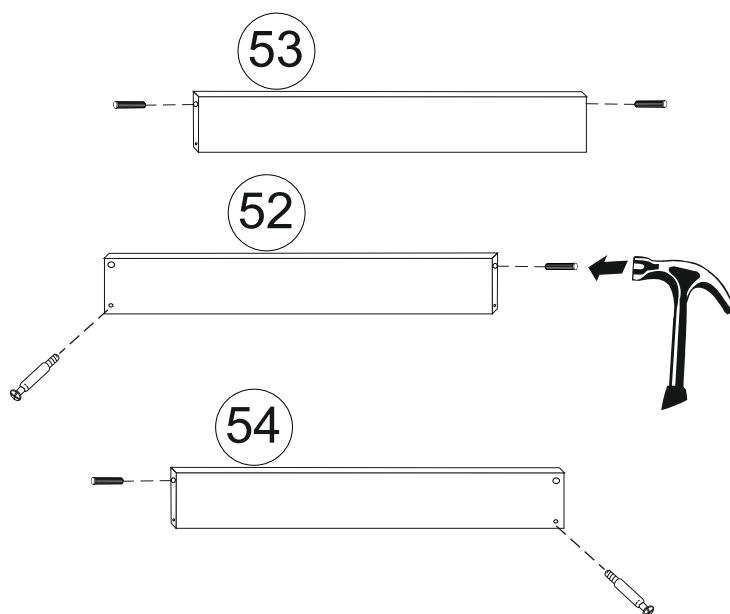
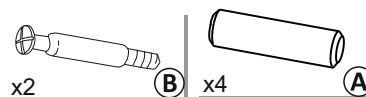

3

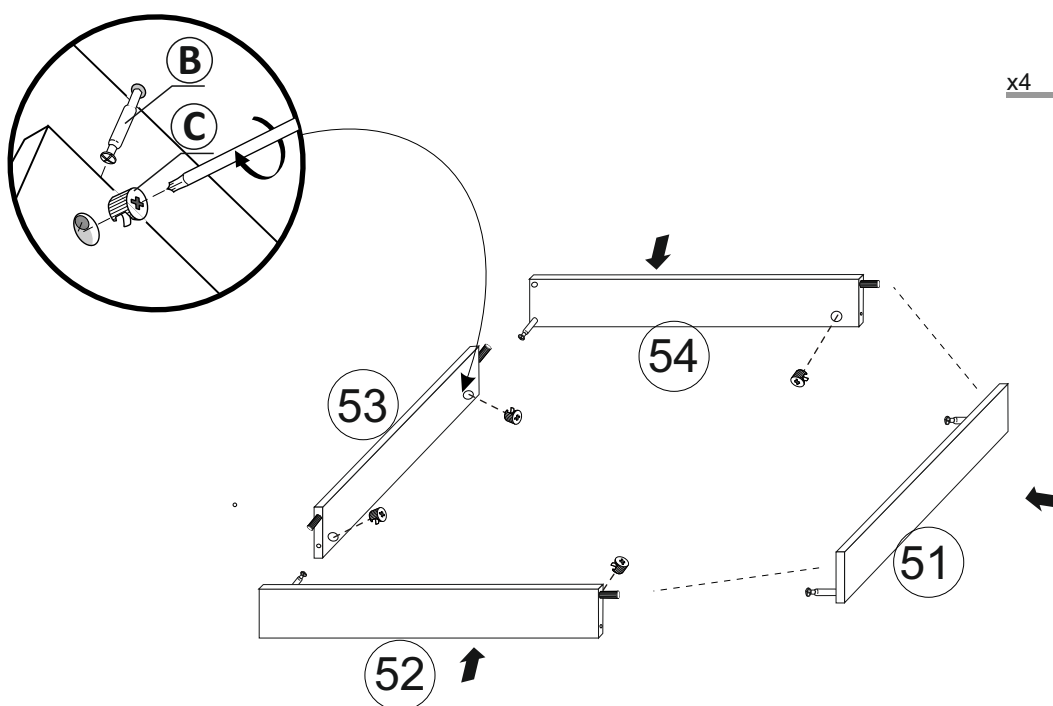
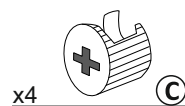

+S

4

PRALNIA HOLV CZ2

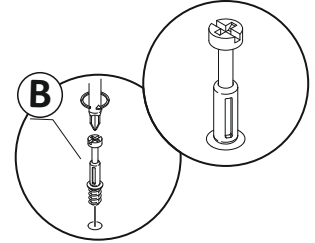
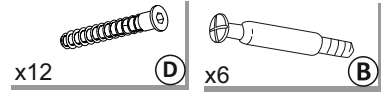
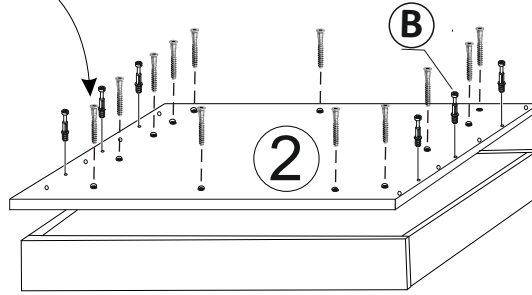
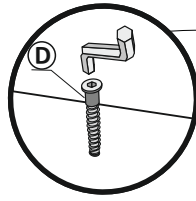

5

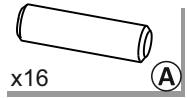
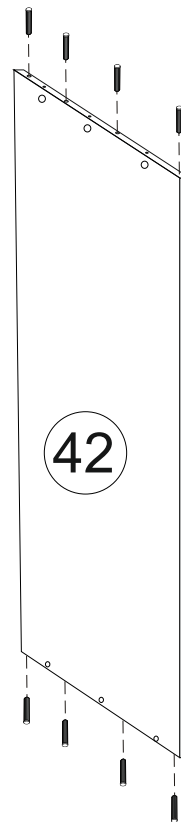
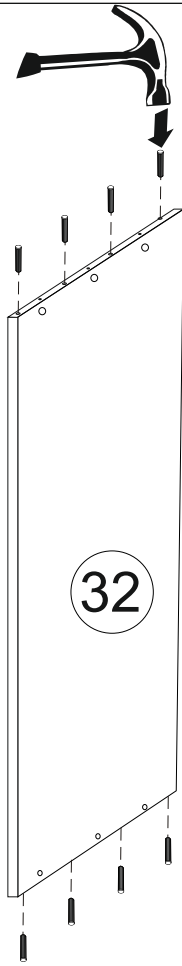

6

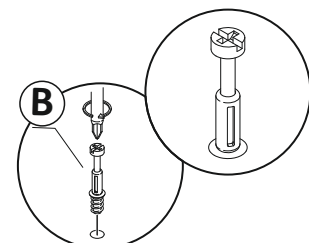
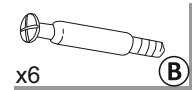
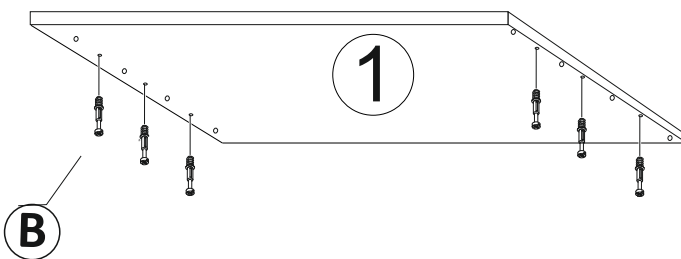

+S

7

PRALNIA HOLV CZ2

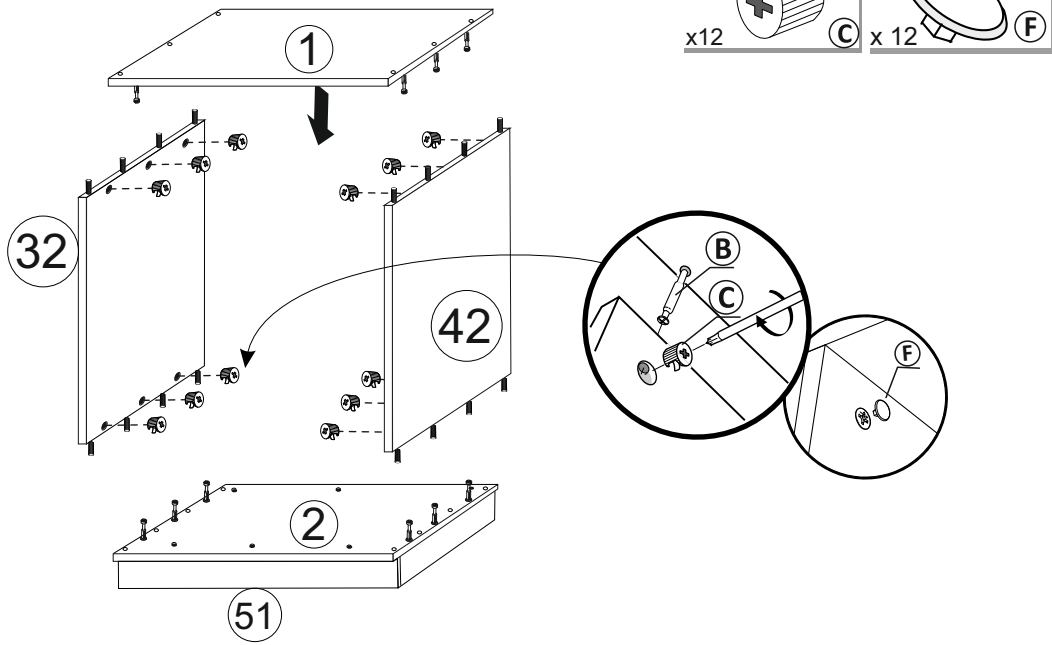

8

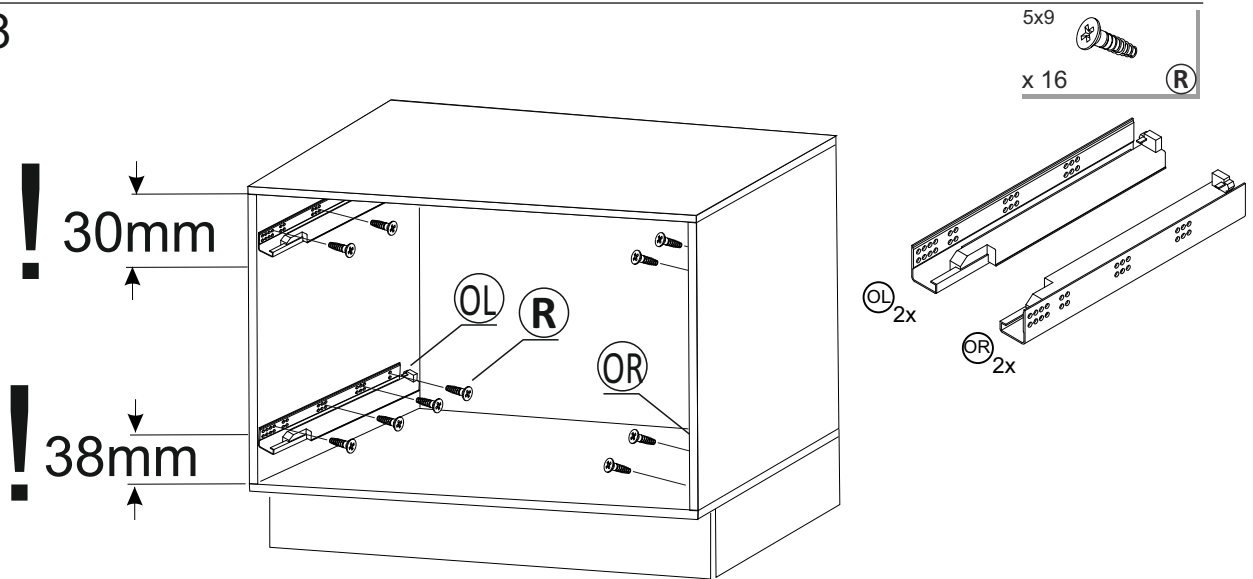

9

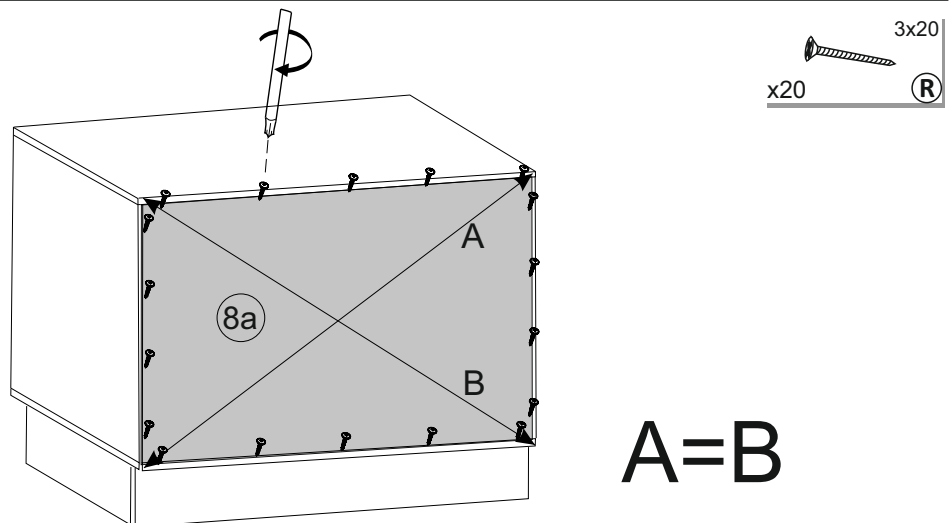

+S

10

PRALNIA HOLV CZ2

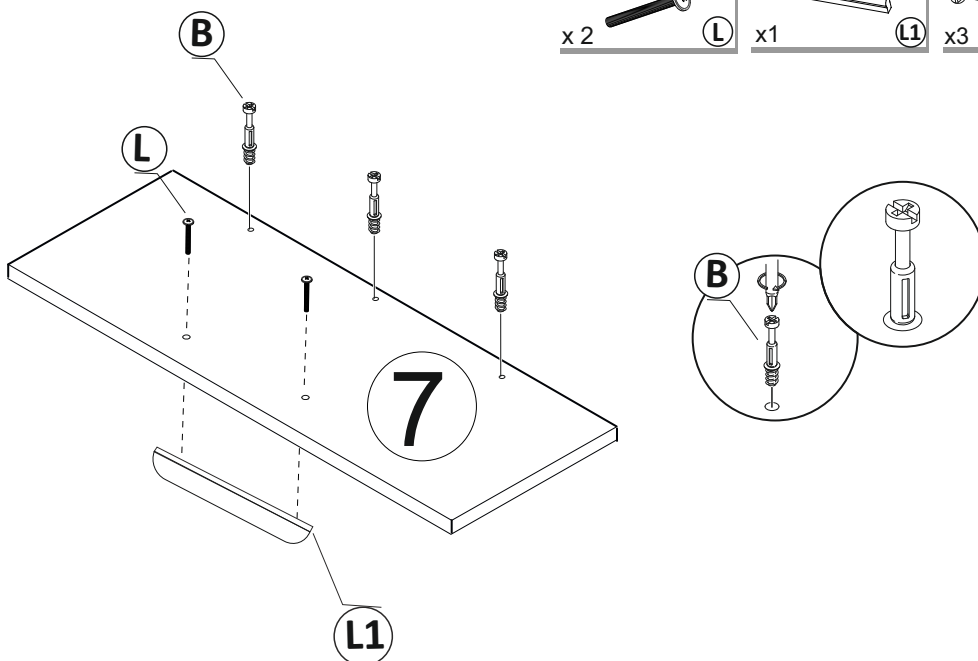

11

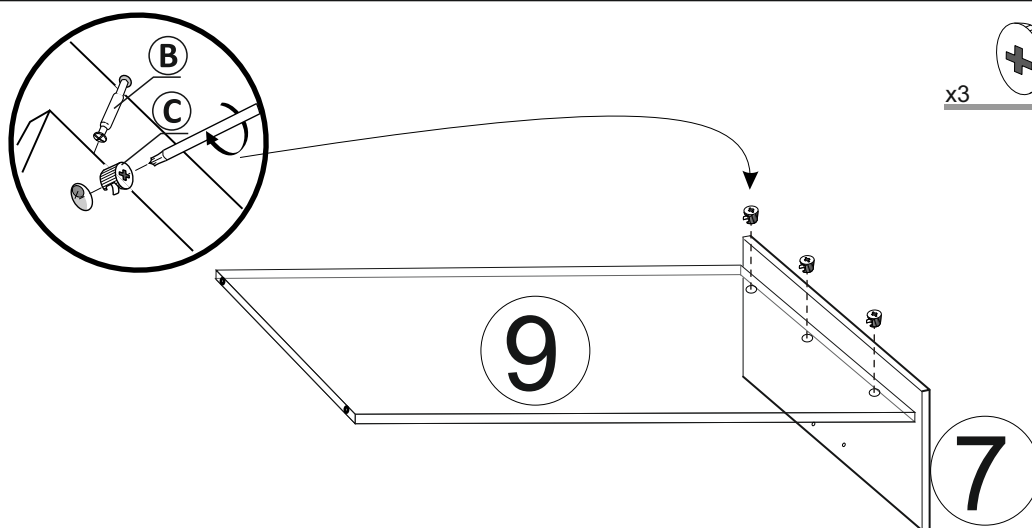
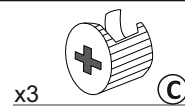

12

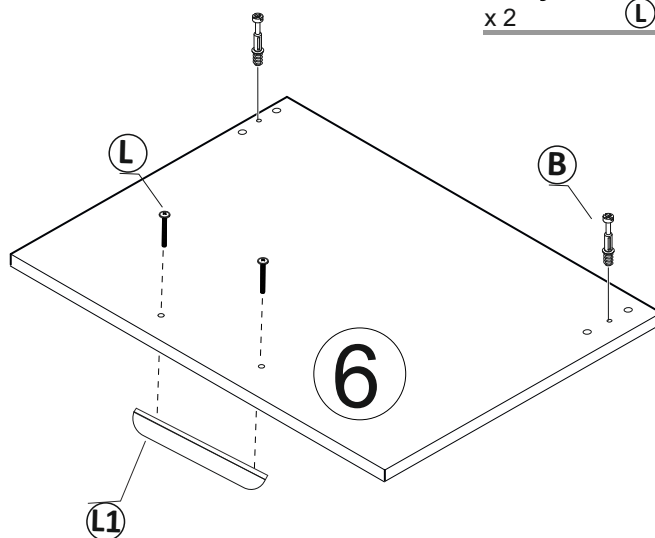

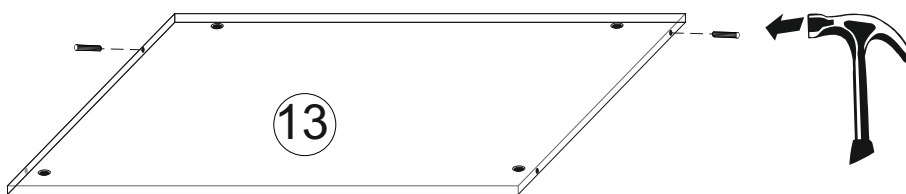

14

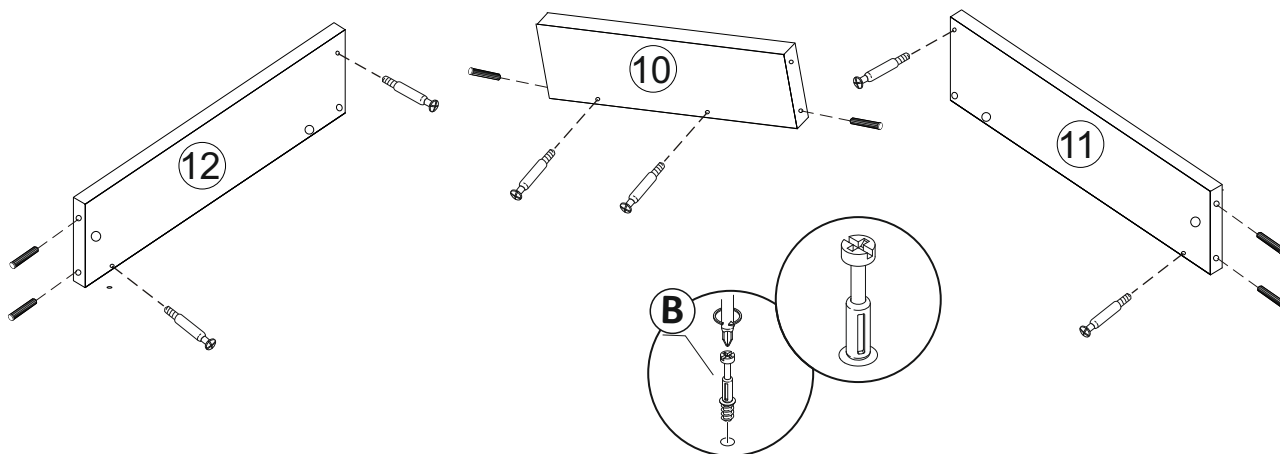
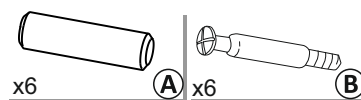

15

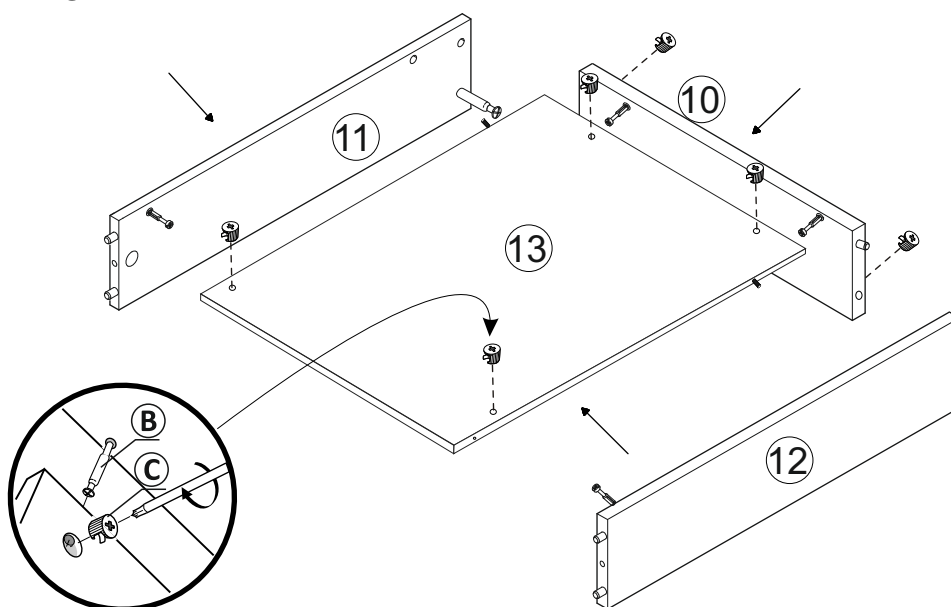
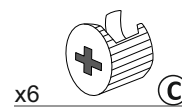

+S

16

PRALNIA HOLV CZ2

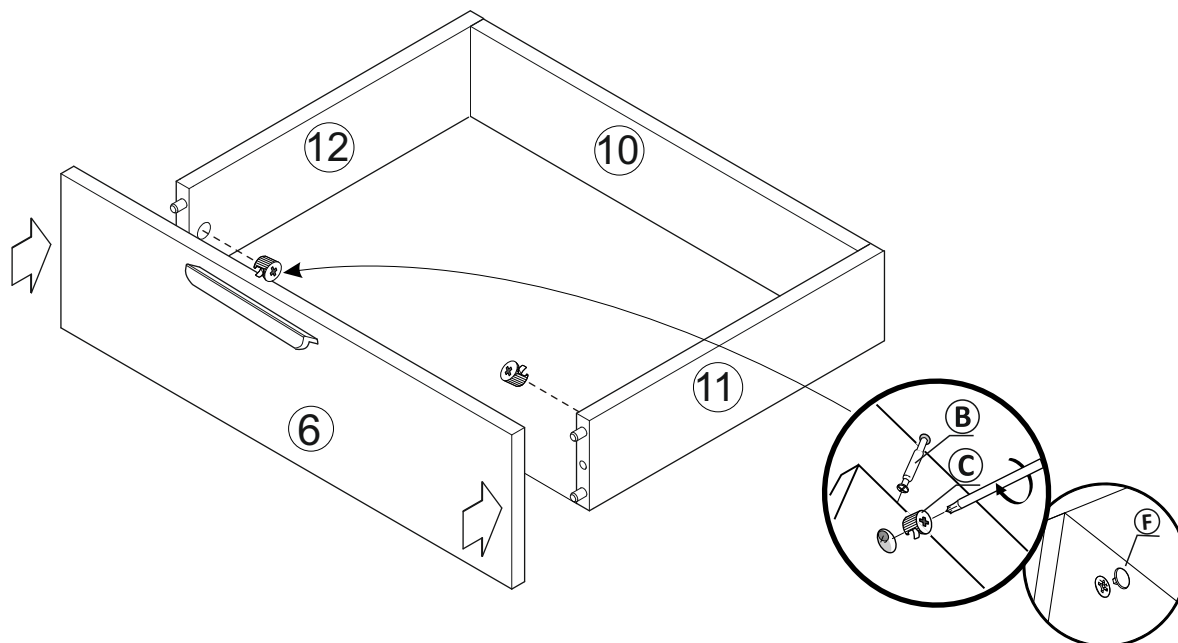
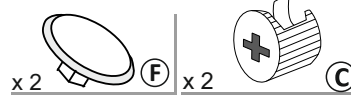

17

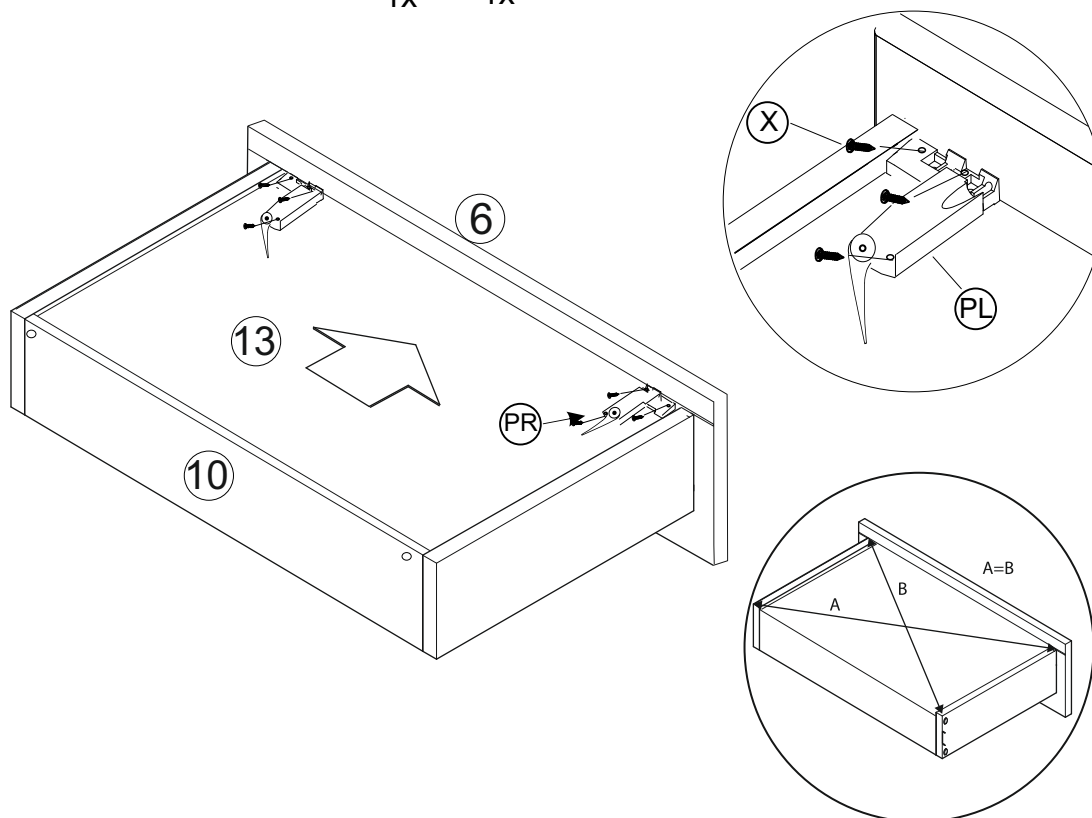
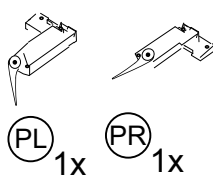
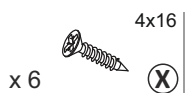

+S

PRALNIA HOLV CZ2

18

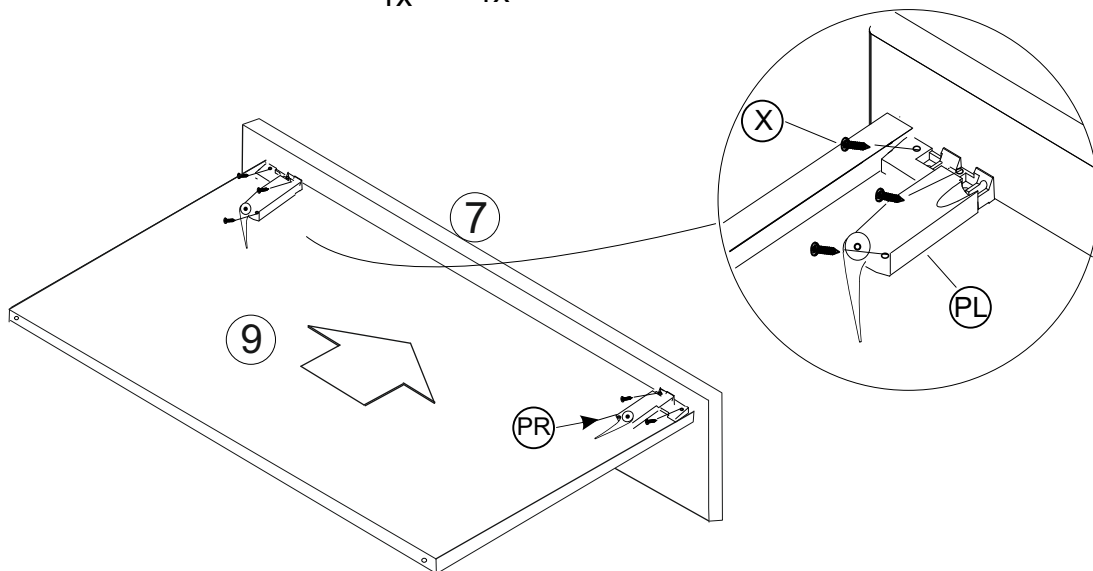
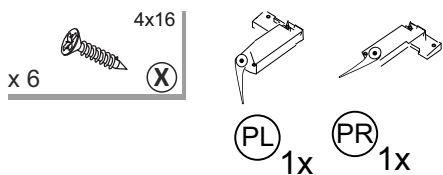

19

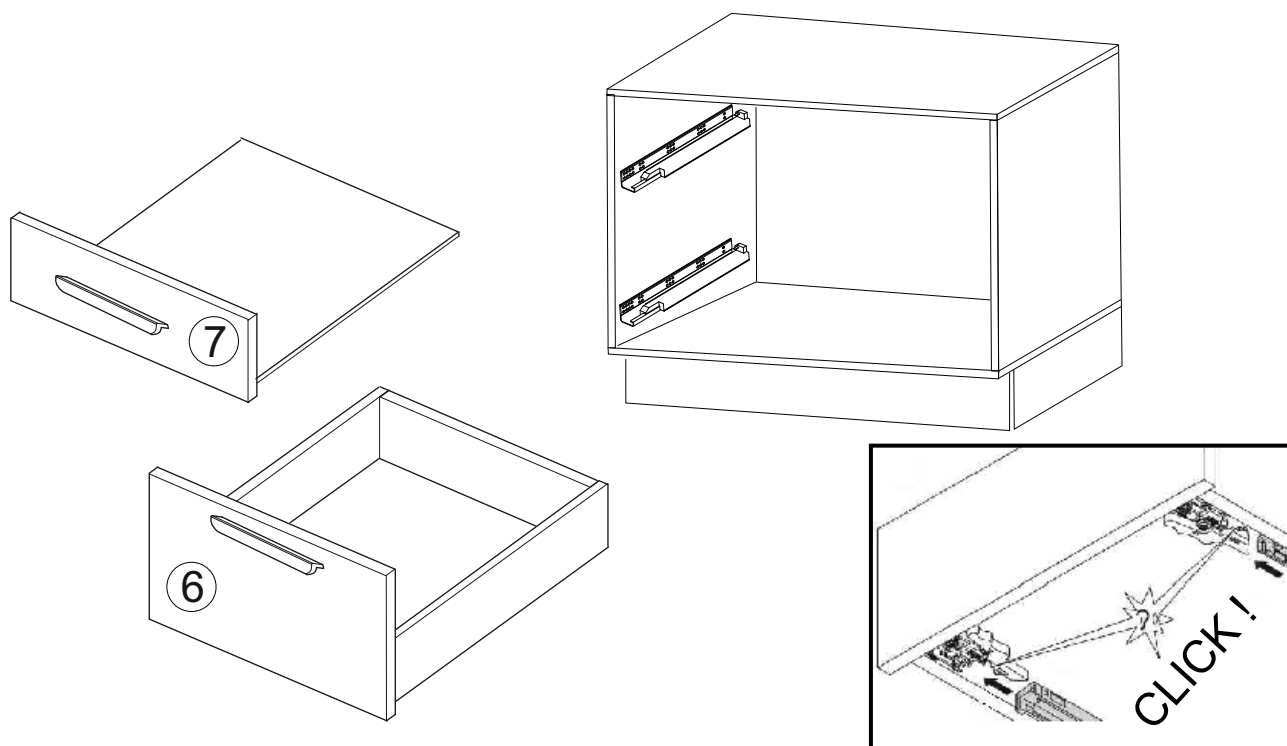

PRALNIA HOLV CZ2

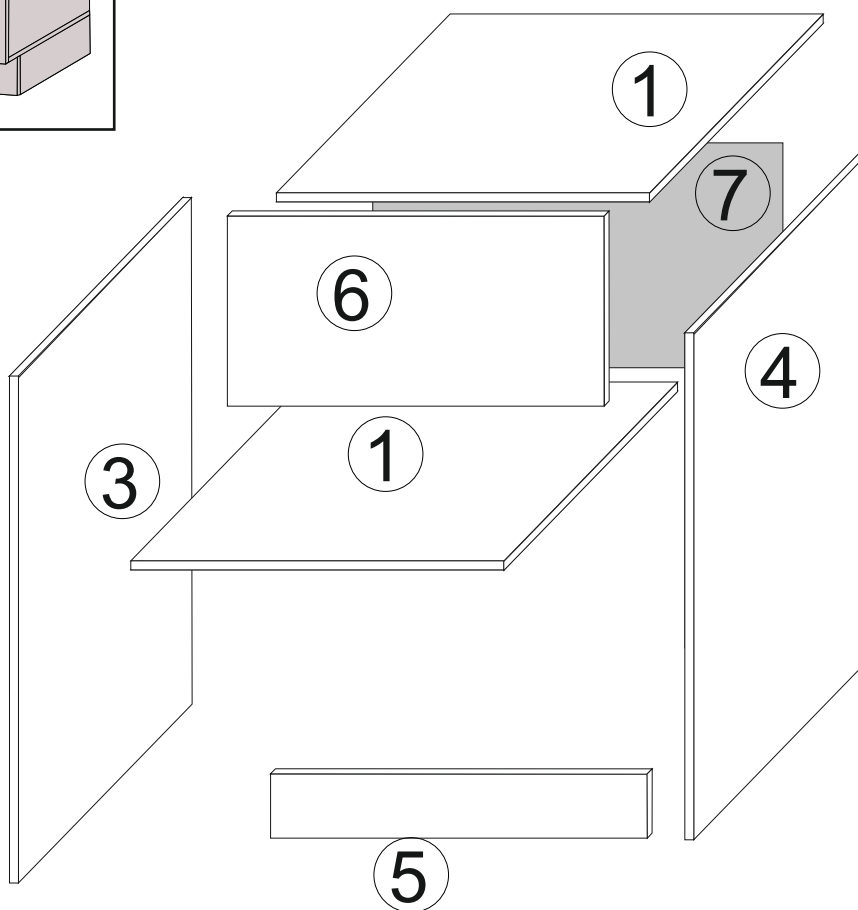
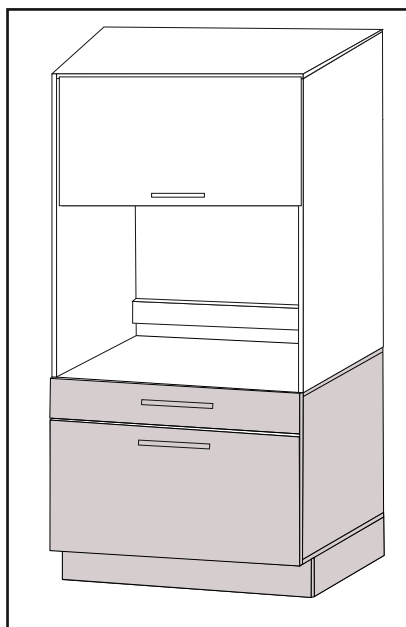
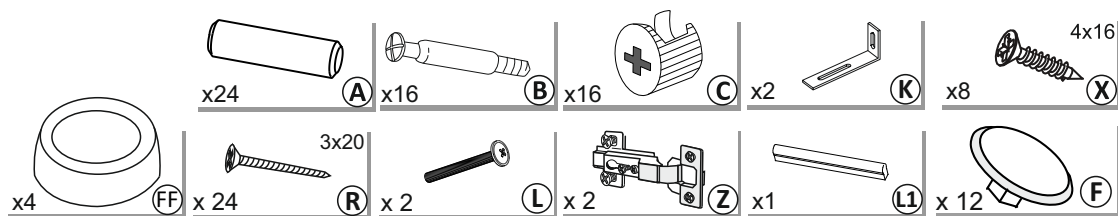

PRALNIA HOLV CZ2

20

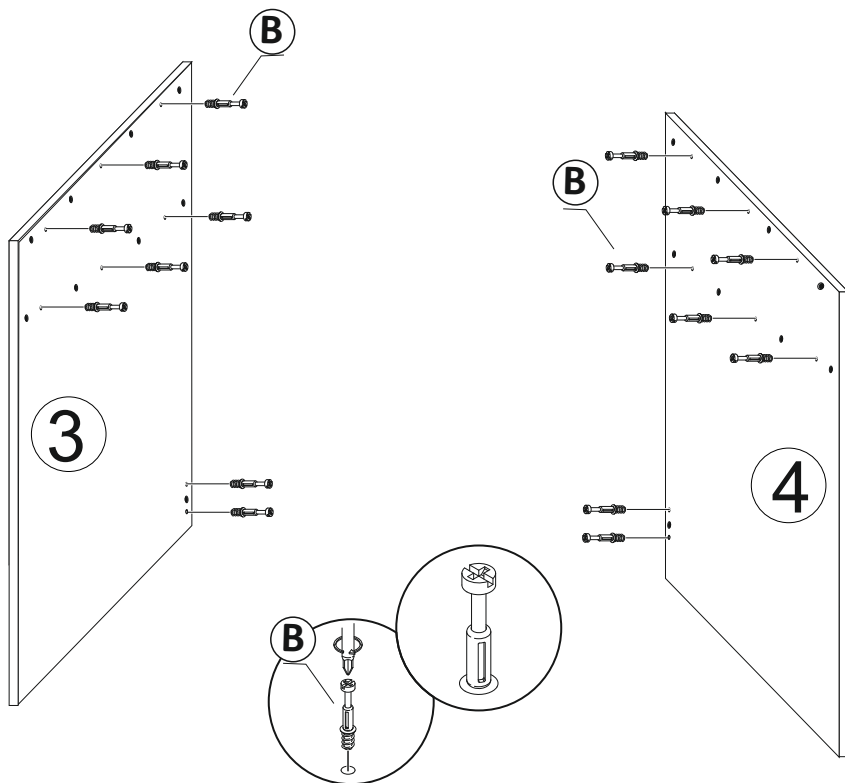
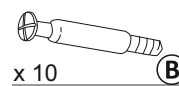

21

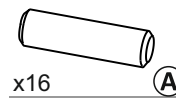

2x

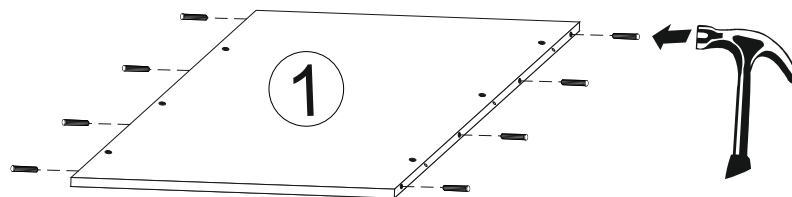

22

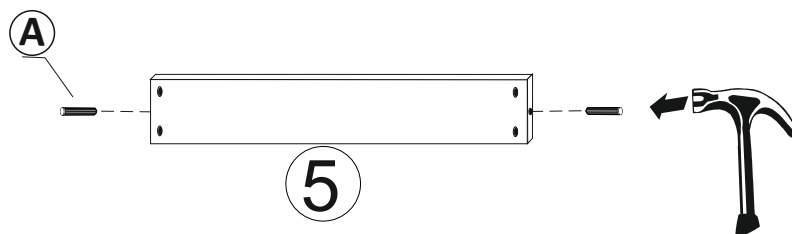

PRALNIA HOLV CZ2

23

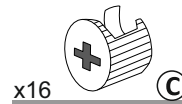
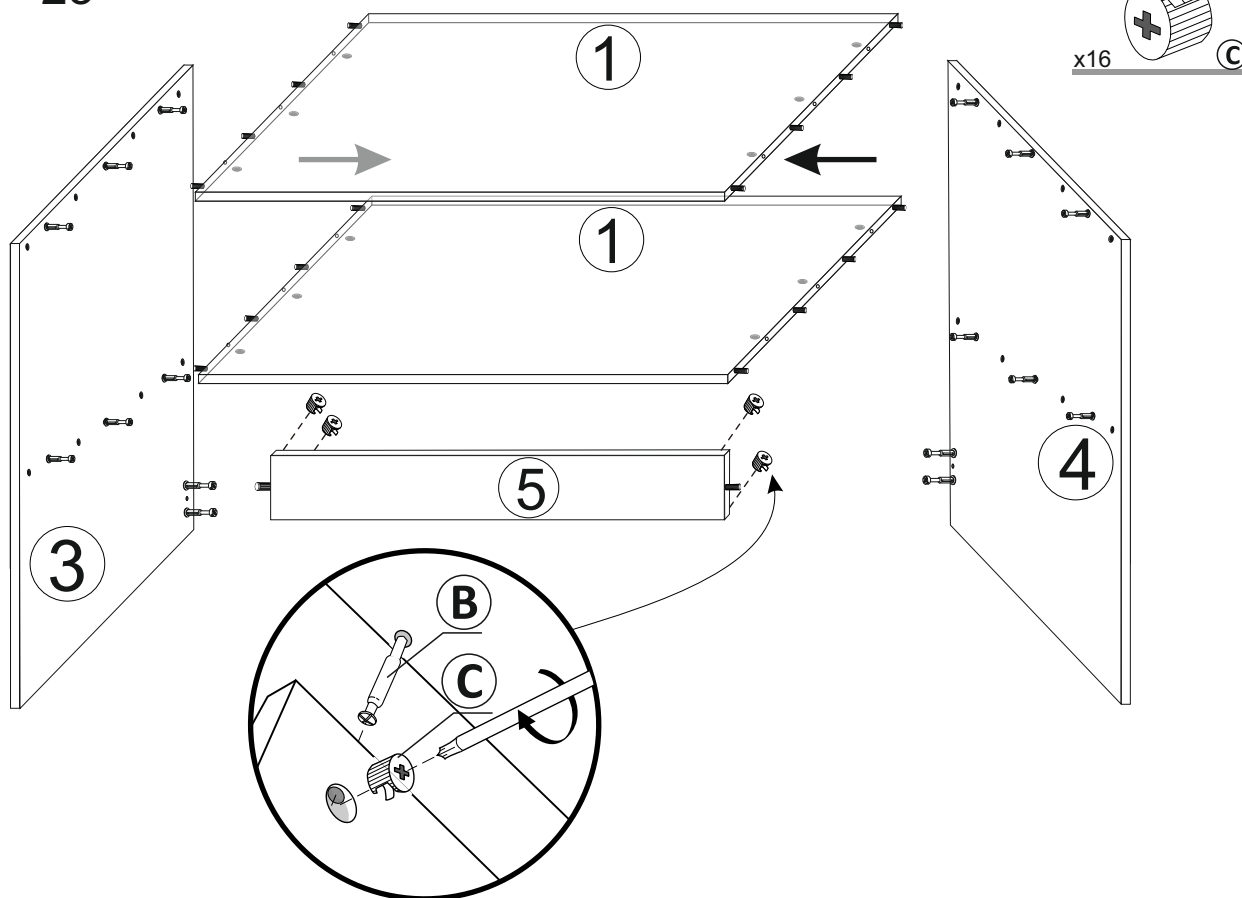

24

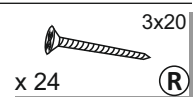
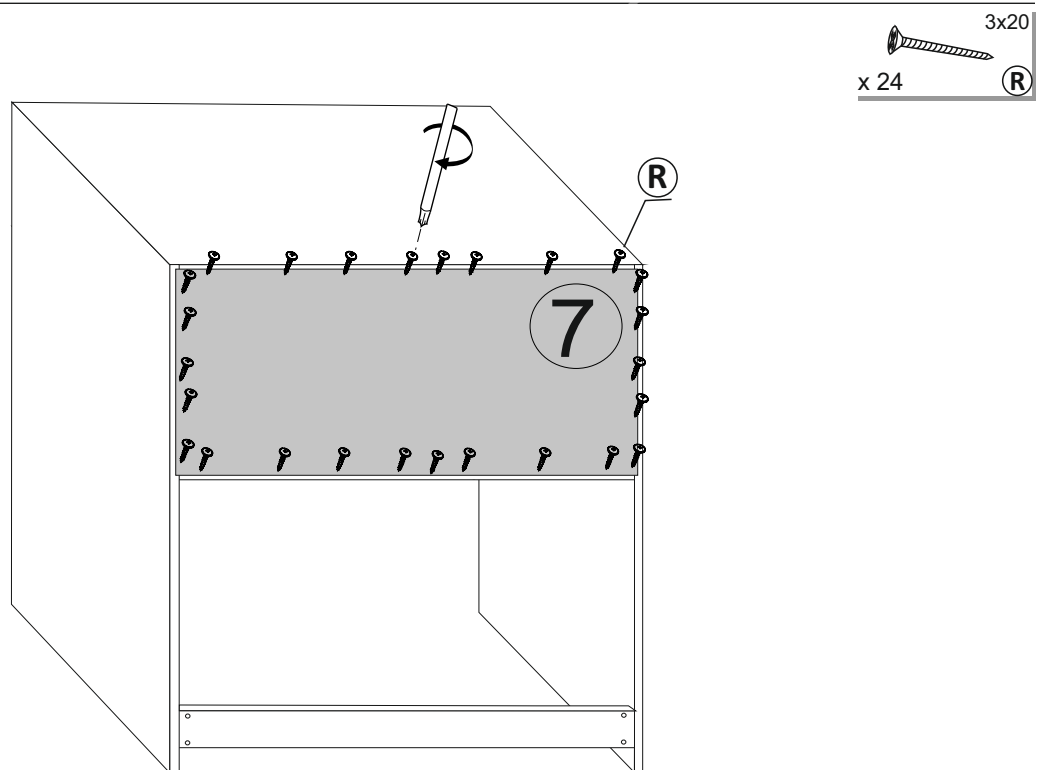

PRALNIA HOLV CZ2

25

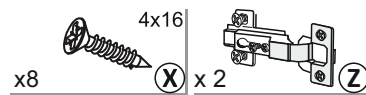
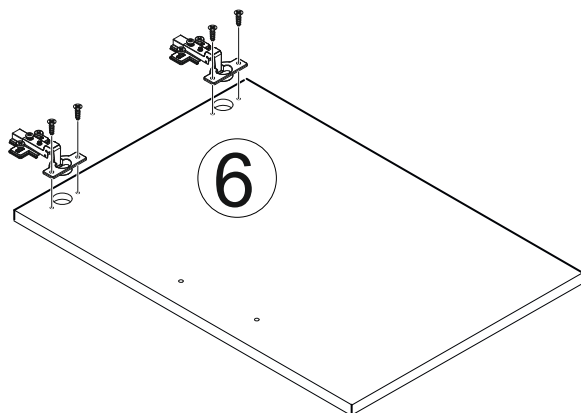

26

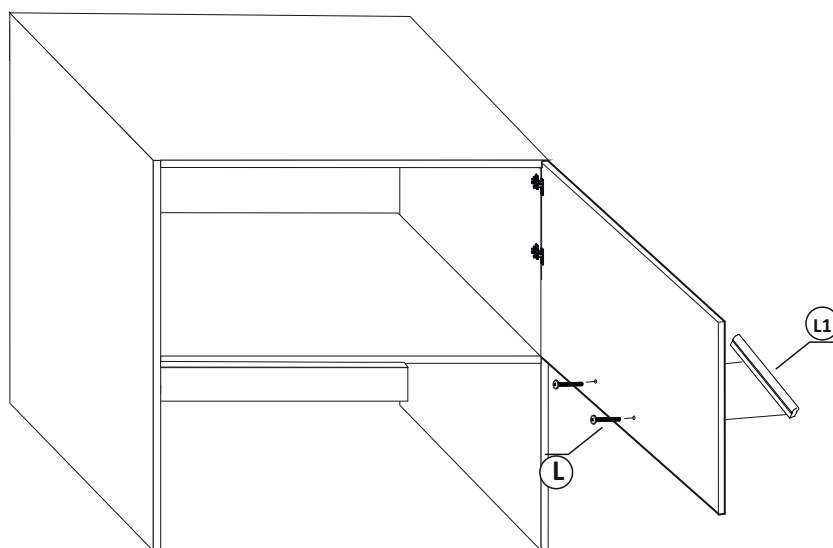
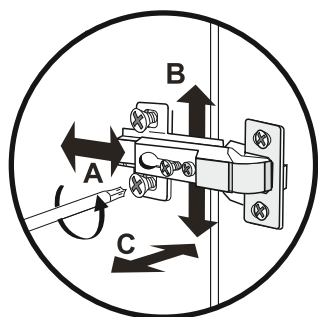
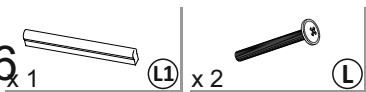

27



PRALNIA CZ.3

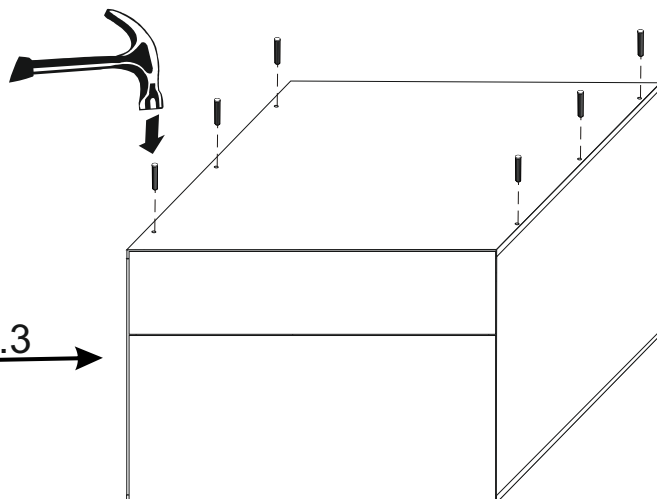

PRALNIA HOLV CZ2

29

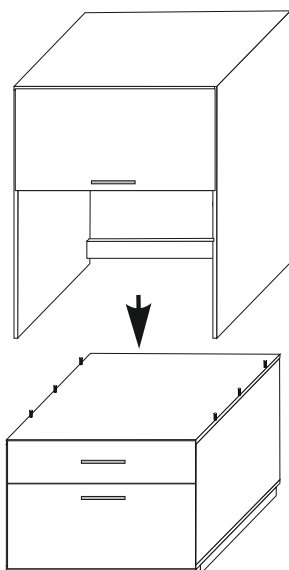

30

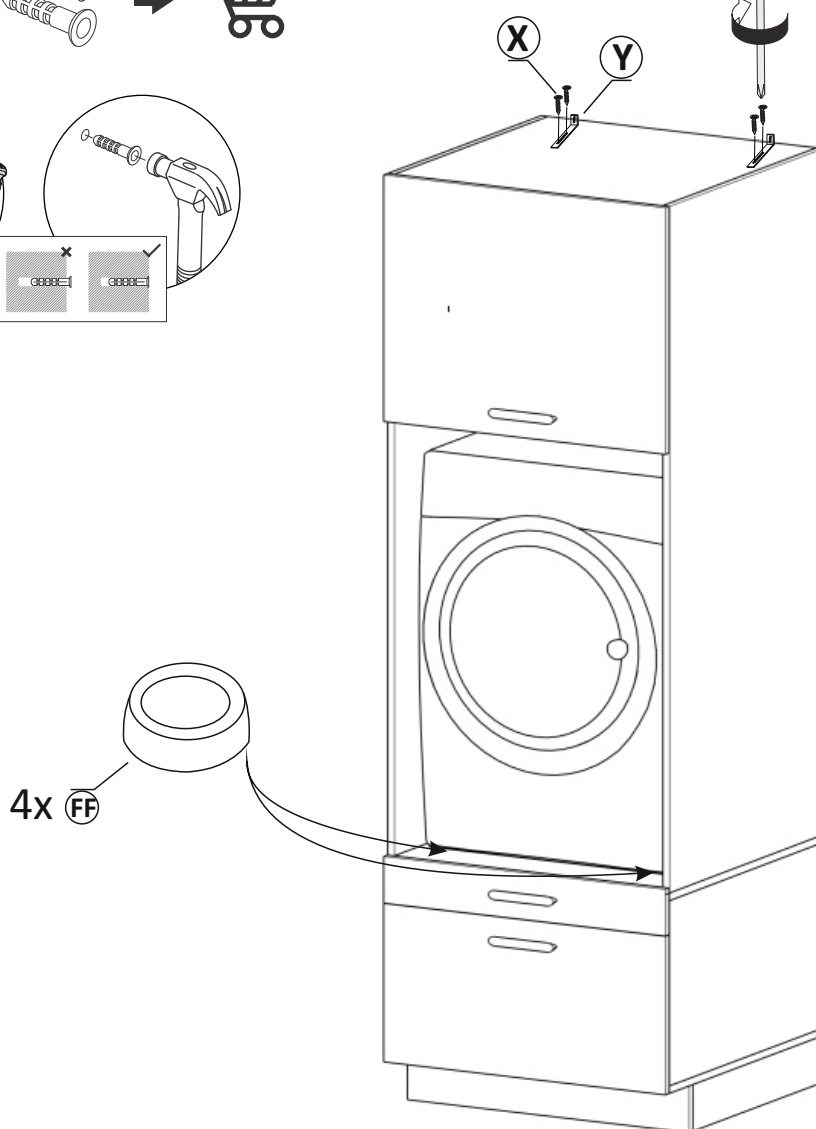
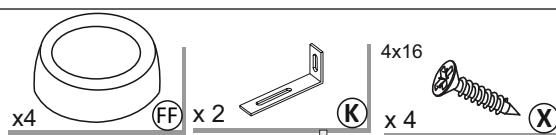
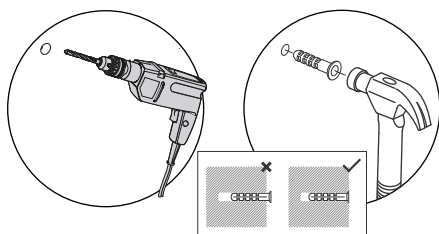

+ Dobrego wnętrza!

Ten produkt został zaprojektowany przez zespół projektantów Selsey Design i wyprodukowany w Polsce.

+ Have a great interior

This product was designed by the Selsey Design team and manufactured in Poland.

+ Ein gutes Zuhause!

Dieses Produkt wurde vom Selsey Design-Team entworfen und in Polen hergestellt.

+ ¡Buen interior!

Este producto fue diseñado por el equipo de Selsey Design y fabricado en Polonia.

+ Een goed interieur!

Dit product is ontworpen door het team van Selsey Design en geproduceerd in Polen.

+ Buon ambiente della casa!

Questo prodotto è stato progettato dal team di Selsey Design e prodotto in Polonia.

+ Un bon intérieur!

Ten produkt został zaprojektowany przez zespół projektantów Selsey Design i wyprodukowany w Polsce.

+ Dobré interiér!

Tento produkt byl navržen týmem Selsey Design a vyroben v Polsku.