

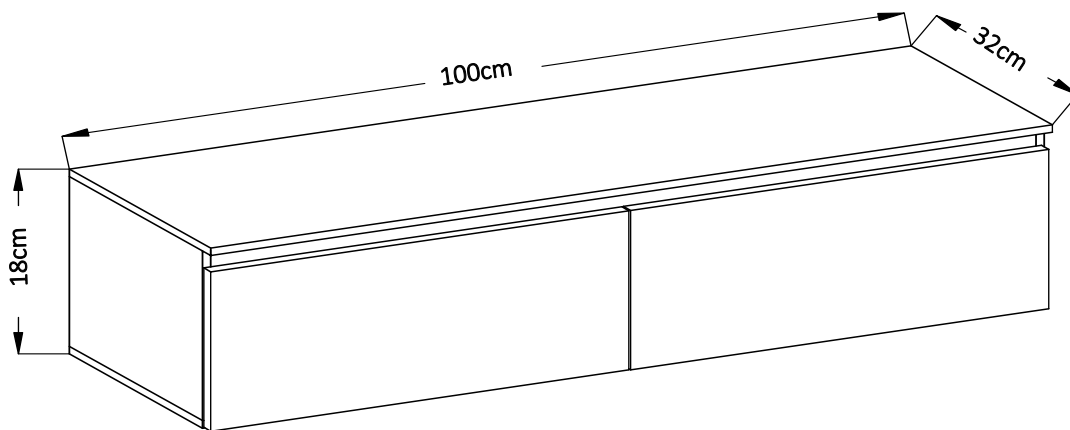

# BEMMI

RTV 100 SLIM



- Zalecamy nie wyrzucać opakowania dopóki nie ukończysz montażu.
- Montażu najlepiej dokonać na miękkiej i czystej powierzchni, takiej jak tekstura, ręcznik, koc.
- Uchroni to przed uszkodzeniem krawędzi mebla.
- Zarówno opakowania plastikowe, jak i okucia trzymaj w miejscu niedostępnym dla niemowląt i dzieci.
- Wszystkie połączenia powinny być odpowiednio dokręcone.
- Przed przystąpieniem do montażu prosimy zapoznać się z całą instrukcją montażu.
- Nie montować elementów, jeśli zauważysz wady lub uszkodzenia.



**PRZED PRZYSTĄPIENIEM DO MONTAŻU SPRAWDŹ, CZY NIE BRAKUJE ŻADNYCH ELEMENTÓW.**

- We recommend not discarding the packaging until assembly is complete.
- Perform assembly on a soft and clean surface, such as cardboard, a towel, or a blanket.
- This will prevent damage to the edges of the furniture.
- Keep both plastic packaging and hardware out of reach of infants and children.
- Ensure all connections are properly tightened.
- Please read the entire assembly manual before starting assembly.
- Do not assemble parts if you notice defects or damage.



**BEFORE STARTING THE ASSEMBLY, CHECK IF ANY PARTS ARE MISSING.**

- Wir empfehlen, die Verpackung nicht zu entsorgen, bevor die Montage abgeschlossen ist.
- Führen Sie die Montage auf einer weichen und sauberen Oberfläche wie Pappe, einem Handtuch oder einer Decke durch.
- Dies verhindert Schäden an den Kanten des Möbelstücks.
- Bewahren Sie sowohl die Plastikverpackungen als auch die Beschläge außerhalb der Reichweite von Säuglingen und Kindern auf.
- Stellen Sie sicher, dass alle Verbindungen festgezogen sind.
- Bitte lesen Sie die gesamte Montageanleitung, bevor Sie mit der Montage beginnen.
- Montieren Sie keine Teile, wenn Sie Mängel oder Schäden feststellen.



**ÜBERPRÜFEN SIE VOR BEGINN DER MONTAGE, OB TEILE FEHLEN.**

- Recomendamos no desechar el embalaje hasta completar el montaje.
- Realice el montaje en una superficie suave y limpia, como cartón, una toalla o una manta.
- Esto evitará daños en los bordes del mueble.
- Mantenga tanto los embalajes de plástico como las piezas fuera del alcance de bebés y niños.
- Asegúrese de que todas las conexiones estén correctamente apretadas.
- Lea todo el manual de montaje antes de comenzar.
- No monte las piezas si nota defectos o daños.



**ANTES DE COMENZAR EL MONTAJE, VERIFICA SI FALTA ALGUNA PIEZA.**

Kraj pochodzenia: Polska  
Country of origin: Poland

Herkunftsland: Polen  
País de origen: Polonia

**PRODUCENT | HERSTELLER | FABRIKANT | FABRICANT  
MANUFACTURER | FABRICANTE | PRODUTTORE | VÝROBCE:**

MILOMAR  
UL. SŁONECZNA 17A  
56-504 Dziadowa kłoda

- Wij raden aan de verpakking niet weg te gooien totdat de montage is voltooid.
- Voer de montage uit op een zachte en schone ondergrond, zoals karton, een handdoek of een deken.
- Dit voorkomt beschadiging van de randen van het meubel.
- Houd zowel plastic verpakkingen als beslag buiten het bereik van baby's en kinderen.
- Zorg ervoor dat alle verbindingen goed zijn aangedraaid.
- Lees de volledige montagehandleiding voordat u begint.
- Monteer geen onderdelen als u gebreken of schade opmerkt.



**CONTROLEER VÓÓR DE MONTAGE OF ER ONDERDELEN ONTBREKEN.**

- Si consiglia di non gettare l'imballaggio fino al completamento del montaggio.
- Eseguire il montaggio su una superficie morbida e pulita, come cartone, asciugamano o coperta.
- Questo proteggerà i bordi del mobile da eventuali danni.
- Tenere sia gli imballaggi in plastica che la ferramenta fuori dalla portata di neonati e bambini.
- Assicurarsi che tutte le connessioni siano adeguatamente serrate.
- Si prega di leggere attentamente l'intero manuale di montaggio prima di iniziare.
- Non montare i componenti se si notano difetti o danni.



**PRIMA DI PROCEDERE CON IL MONTAGGIO, VERIFICA SE MANCANO DEI PEZZI.**

- Nous recommandons de ne pas jeter l'emballage avant d'avoir terminé le montage.
- Assemblez sur une surface douce et propre, comme du carton, une serviette ou une couverture.
- Cela évitera d'endommager les bords du meuble.
- Gardez les emballages en plastique et les fixations hors de portée des nourrissons et des enfants.
- Assurez-vous que toutes les connexions sont correctement serrées.
- Veuillez lire l'intégralité du manuel d'assemblage avant de commencer.
- Ne montez pas les éléments si vous constatez des défauts ou des dommages.



**AVANT DE COMMENCER LE MONTAGE, VÉRIFIEZ S'IL MANQUE DES PIÈCES.**

- Doporučujeme nevyhazovat obal, dokud nedokončíte montáž.
- Montáž provádějte na měkkém a čistém povrchu, jako je karton, ručník nebo deka.
- To zabrání poškození hran nábytku.
- Uchovávejte plastové obaly i kování mimo dosah kojenců a dětí.
- Ujistěte se, že všechny spoje jsou řádně utaženy.
- Před zahájením montáže si prosím přečtěte celý montážní návod.
- Nemontujte díly, pokud zjistíte vady nebo poškození.



**PŘED ZAHÁJENÍM MONTÁŽE ZKONTROLUJTE, ZDA NECHYBÍ ŽÁDNÉ DÍLY.**









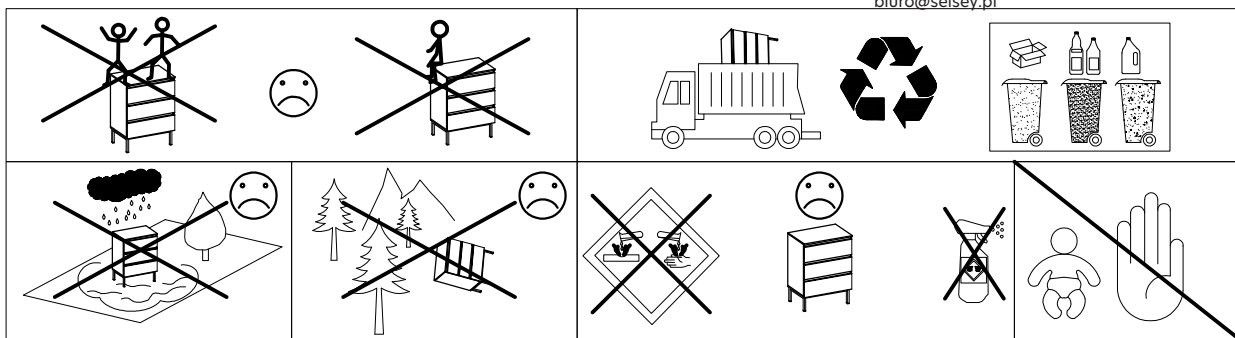





Land van herkomst: Polen  
Paese di origine: Polonia

Pays d'origine: Pologne  
Země původu: Polsko

**DYSTRYBUTOR | VERTRIEBSPARTNER | DISTRIBUTEUR | DISTRIBUTEUR  
DISTRIBUTOR | DISTRIBUIDOR | DISTRIBUTORE | DISTRIBUTOR**

SELSEY Sp. z o.o.  
ul. Fabryczna 6  
53-609 Wrocław  
biuro@selsey.pl



 A7 7	 C 6	 D1 6	 B 6	 O 1	 K14 2	 K10 2	 K11 1	 R8 6
 F1 6	 P25 16	 G10 4	 F10 30	 O11 1				

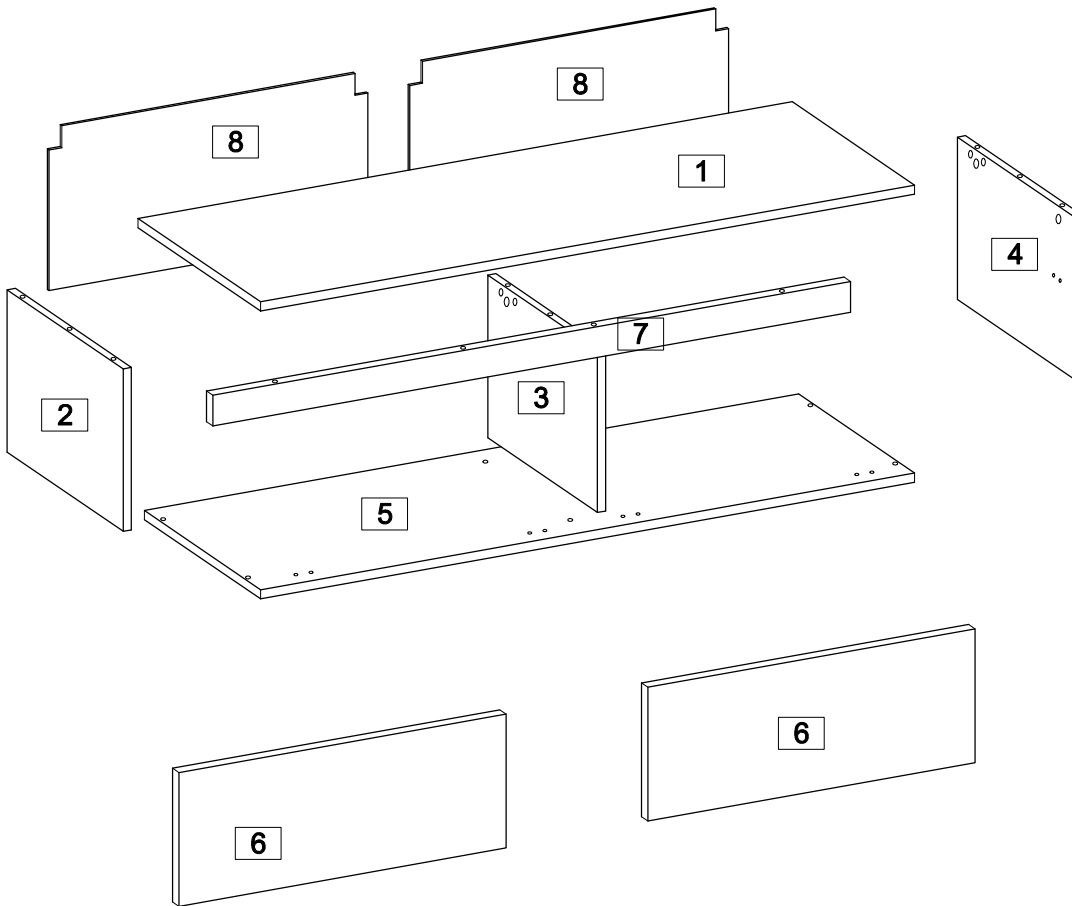

1	2	3	4	5	6	7	8
1000x318x16 mm	150x300x16 mm	150 x279x16 mm	150x300x16 mm	1000x300x16 mm	497x145 x16 mm	966x40 x16 mm	496 x175 x3 mm
1x	1x	1x	1x	1x	2x	1x	2x

+S

# BEMMI

1

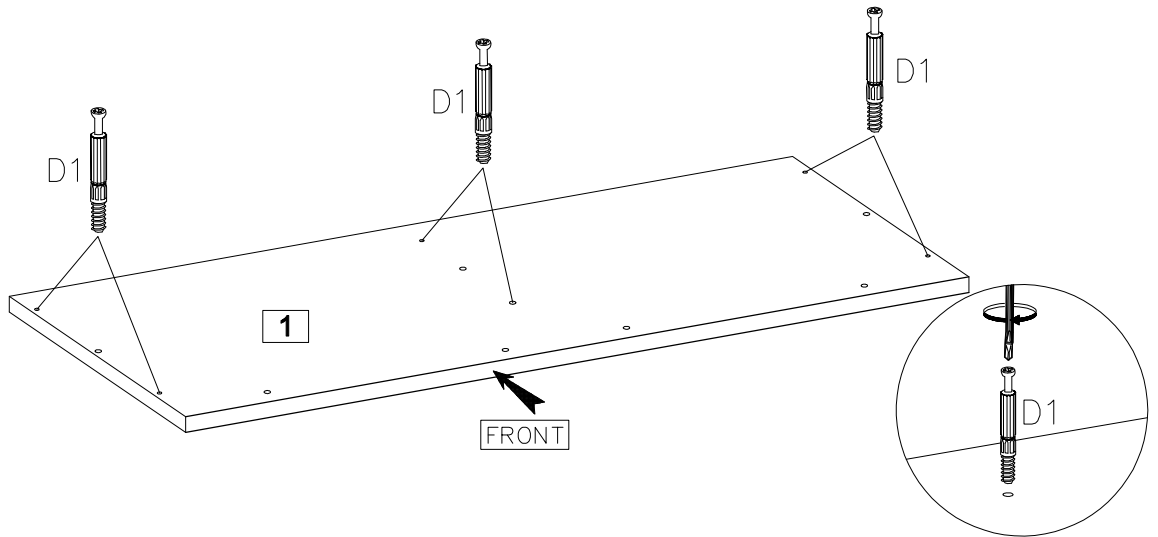
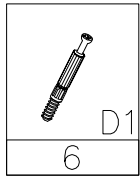

2

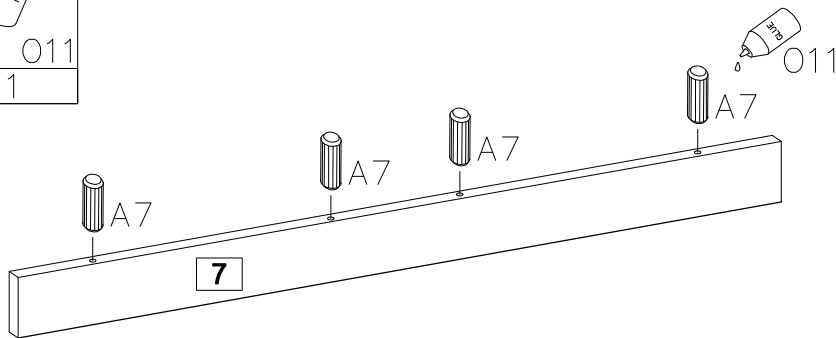
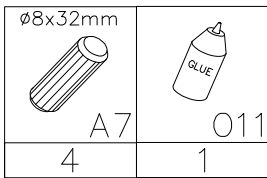

3

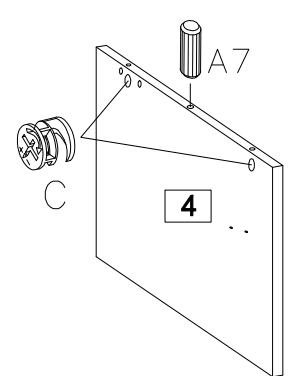
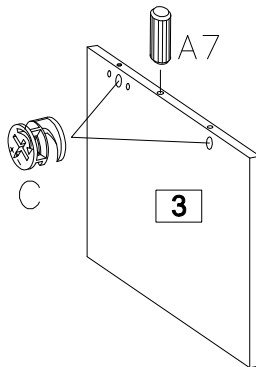
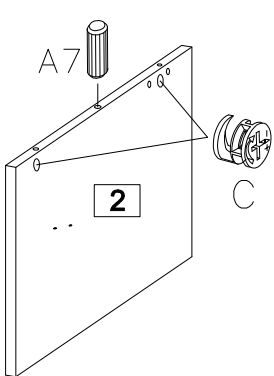
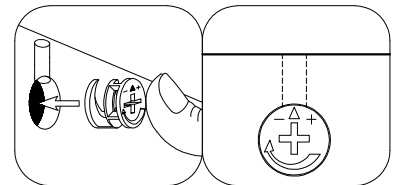
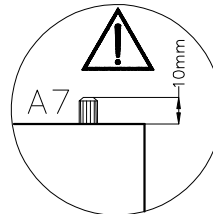
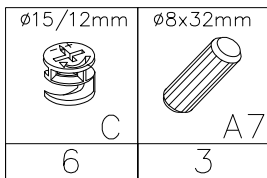

+S

BEMMI

4

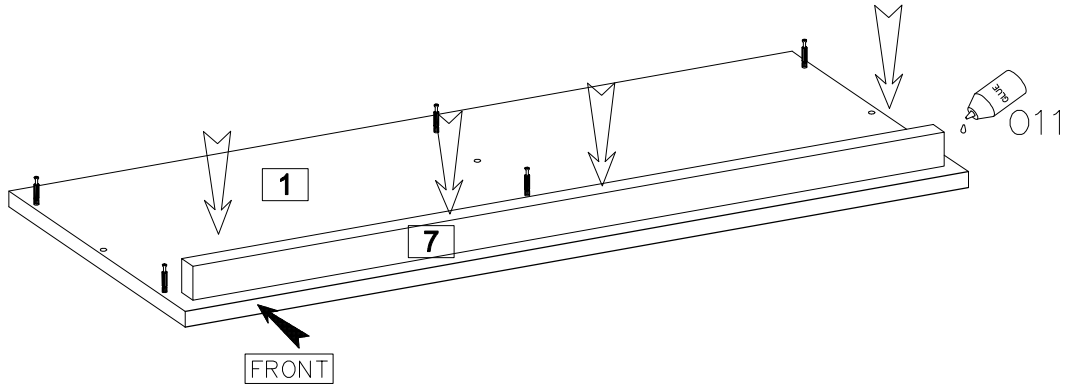
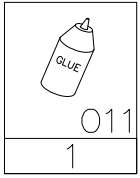

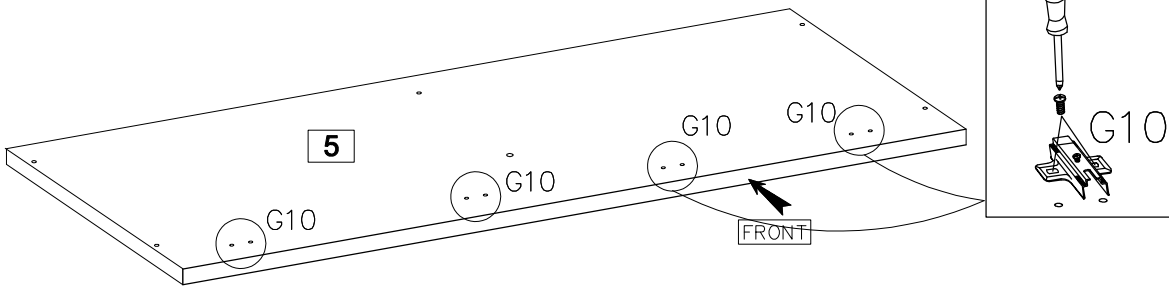
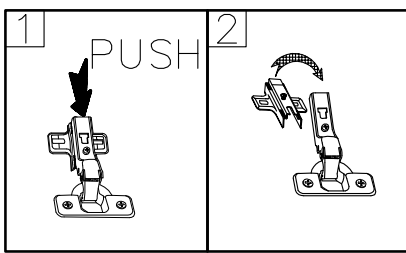
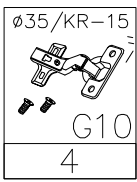

5

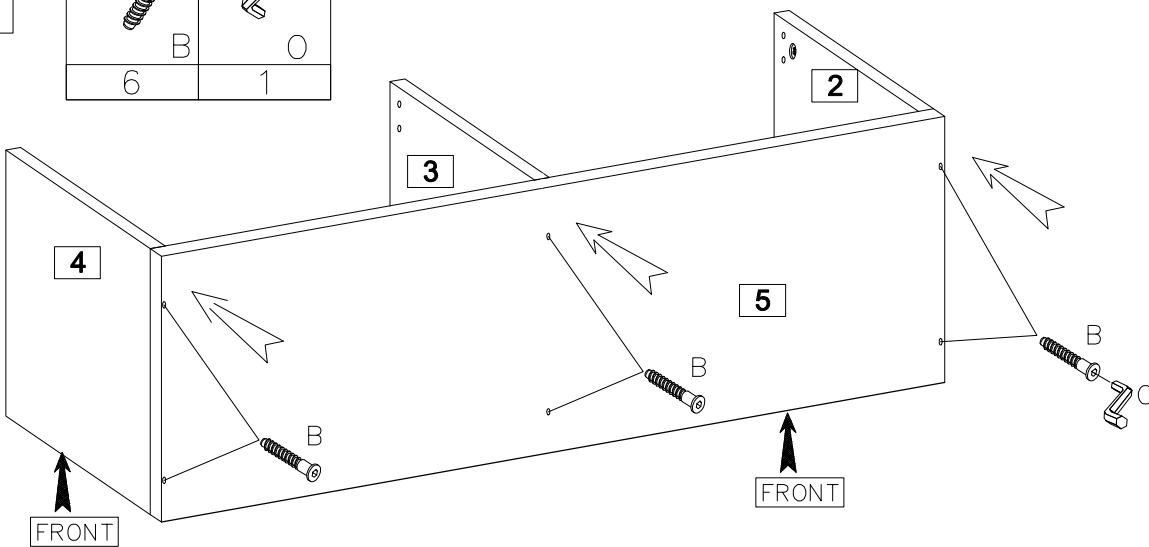
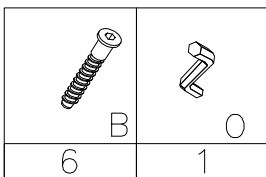

6

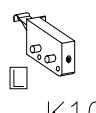
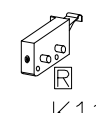

7

 K10 2	 K11 1	 R8 6
---	---	--

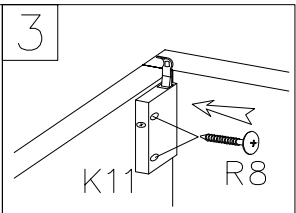
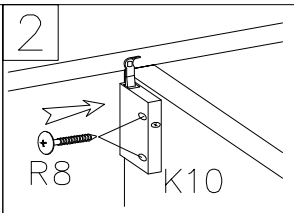
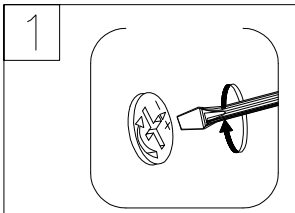

**HANGING VERSION**

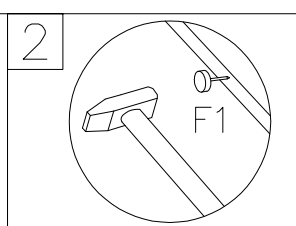
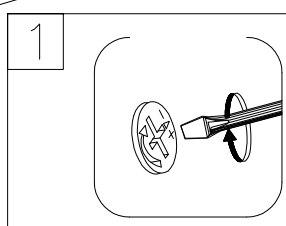
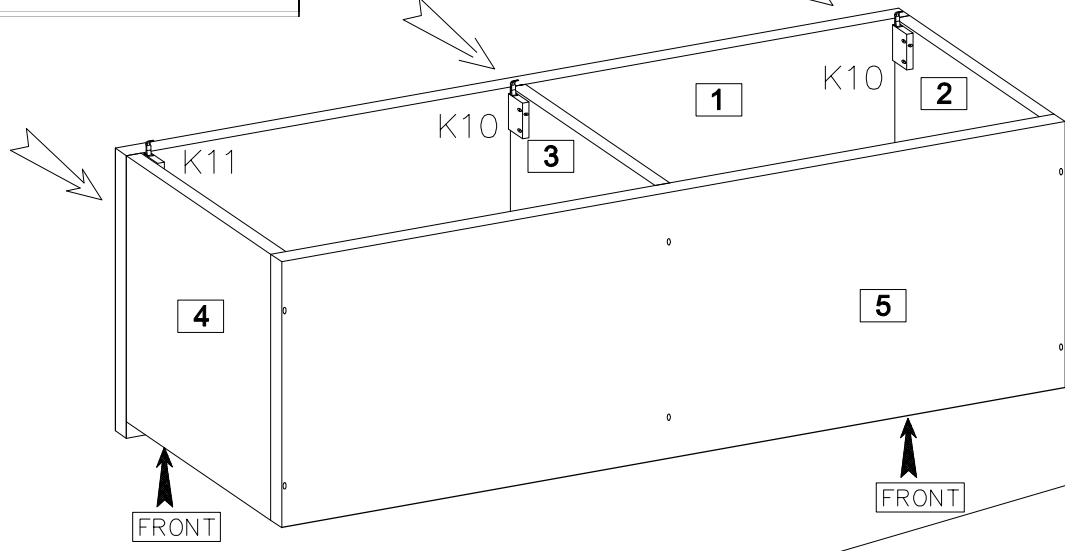

**STANDING VERSION**

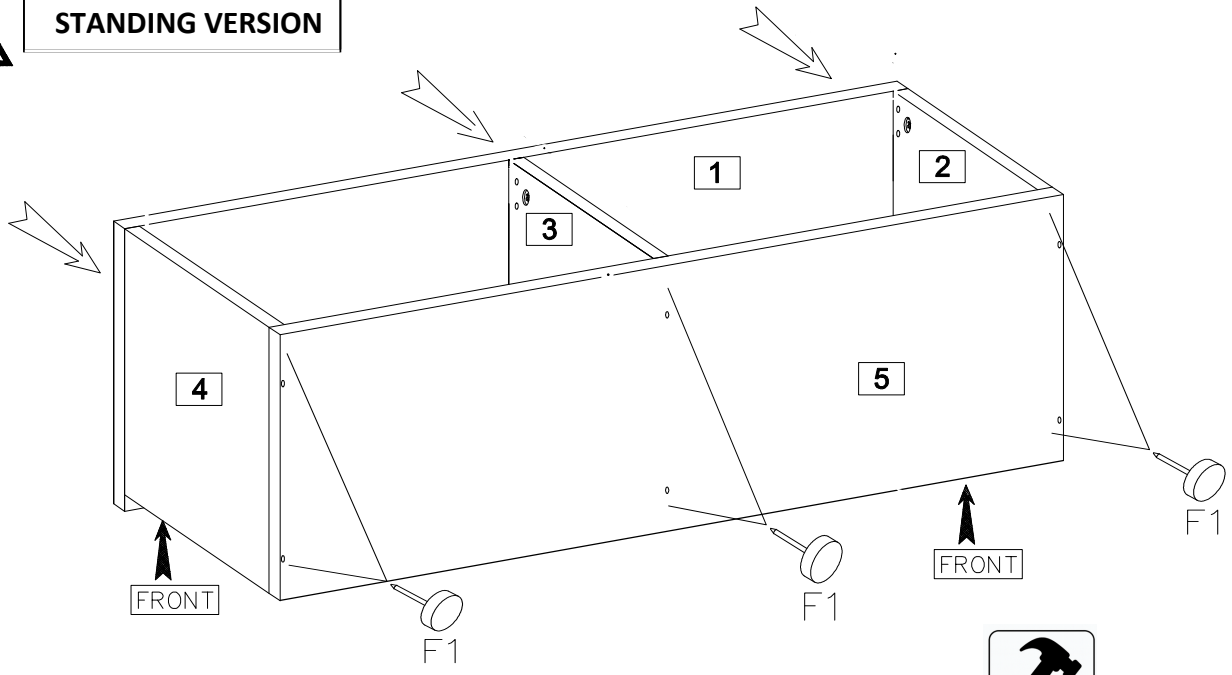

 F1 6
--



+S

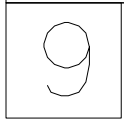
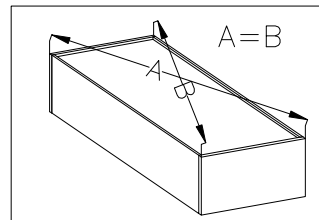
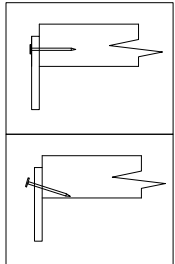
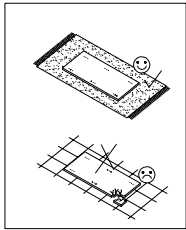
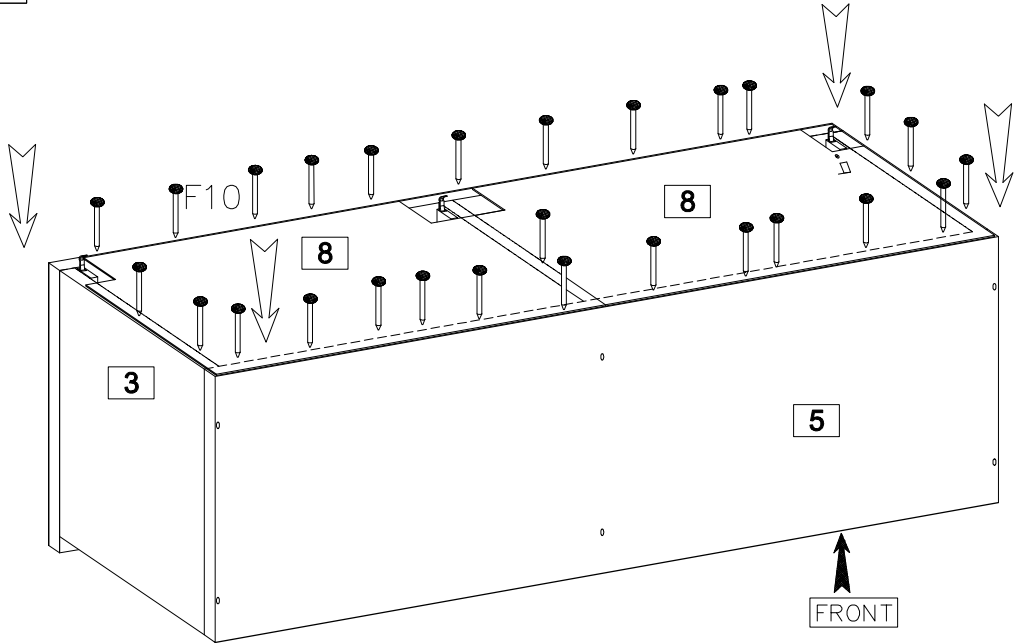
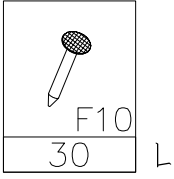
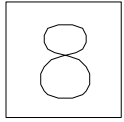

# BEMMI



$\varnothing 3.5 \times 15 \text{mm}$	$\varnothing 35 / \text{KR}-15$
	
P25	G10
8	4



10

∅3.5x15mm		
	P25	K14
	8	2



**HANGING VERSION**

#	X(mm)	Y(mm)
RTV 100	491	458

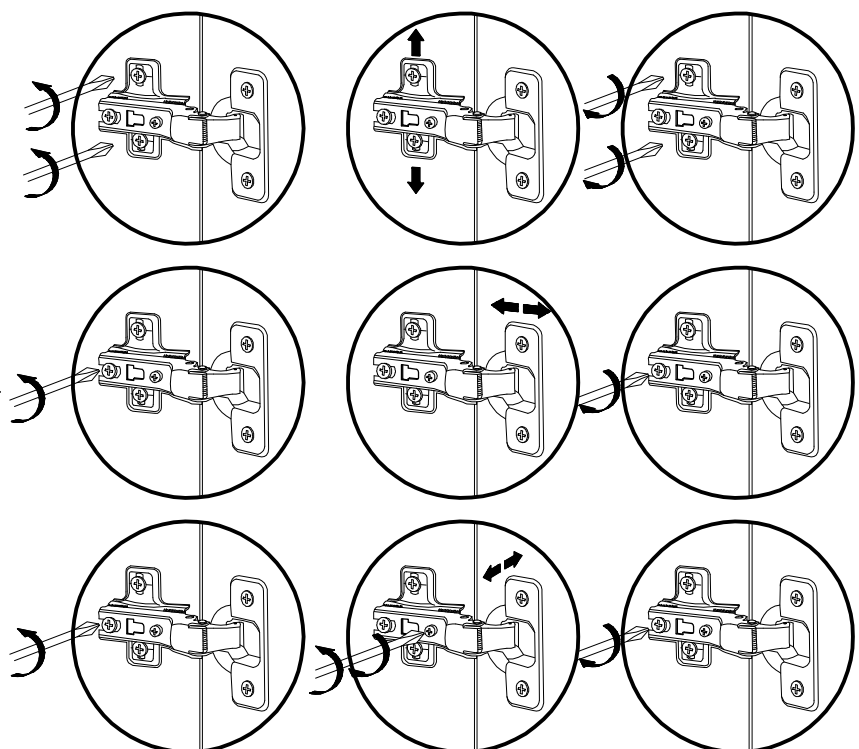
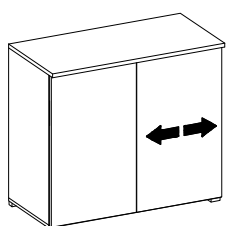
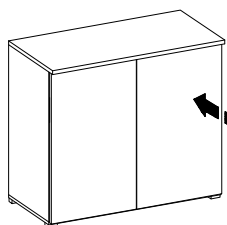
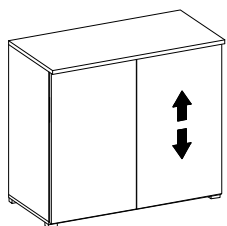
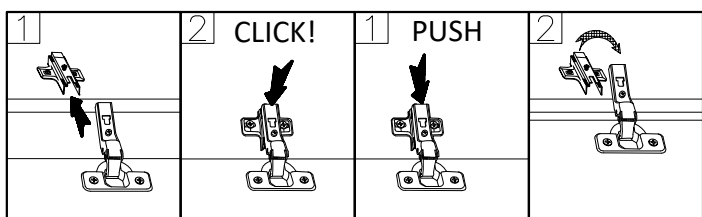
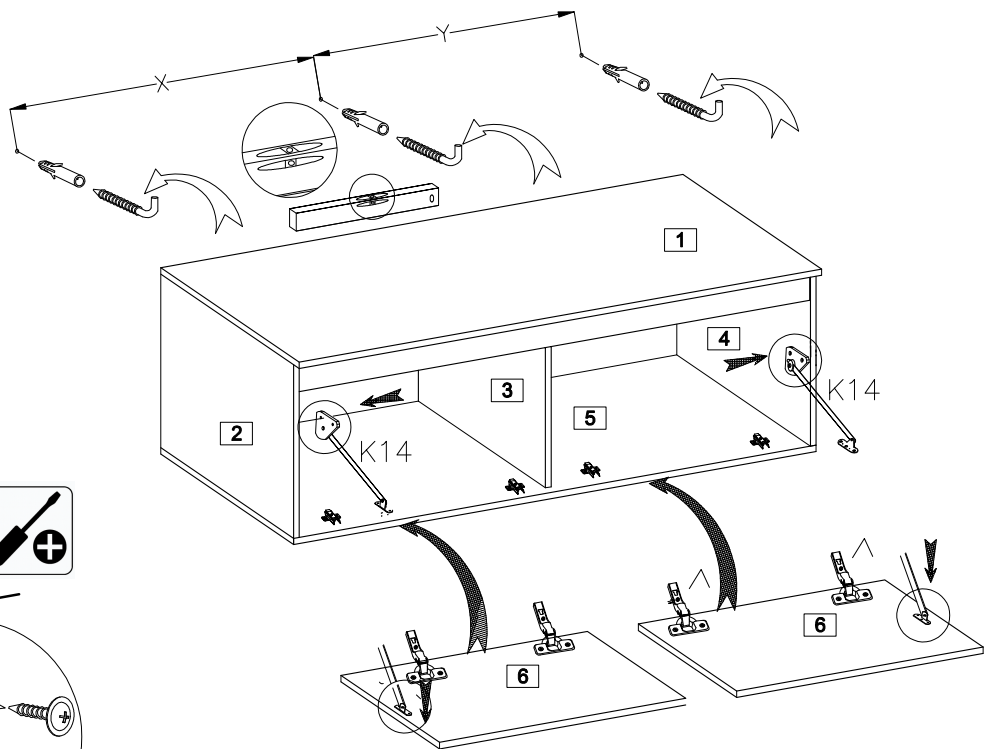
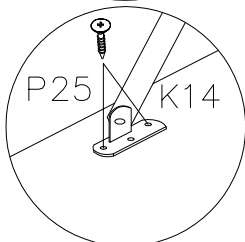
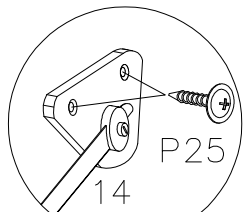
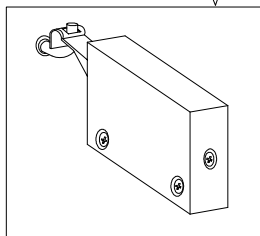
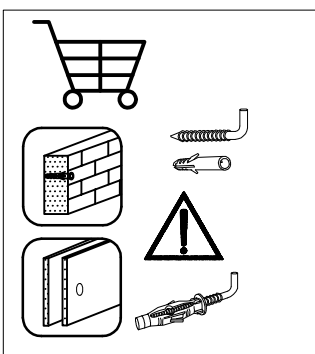
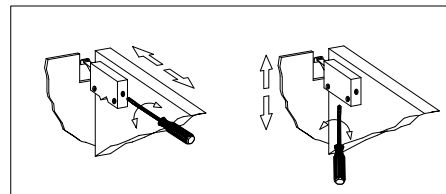

**+ Dobrego wnętrza!**

Ten produkt został zaprojektowany przez zespół projektantów Selsey Design i wyprodukowany w Polsce.

**+ Have a great interior**

This product was designed by the Selsey Design team and manufactured in Poland.

**+ Ein gutes Zuhause!**

Dieses Produkt wurde vom Selsey Design-Team entworfen und in Polen hergestellt.

**+ ¡Buen interior!**

Este producto fue diseñado por el equipo de Selsey Design y fabricado en Polonia.

**+ Een goed interieur!**

Dit product is ontworpen door het team van Selsey Design en geproduceerd in Polen.

**+ Buon ambiente della casa!**

Questo prodotto è stato progettato dal team di Selsey Design e prodotto in Polonia.

**+ Un bon intérieur!**

Ten produkt został zaprojektowany przez zespół projektantów Selsey Design i wyprodukowany w Polsce.

**+ Dobré interiér!**

Tento produkt byl navržen týmem Selsey Design a vyroben v Polsku.