

5589

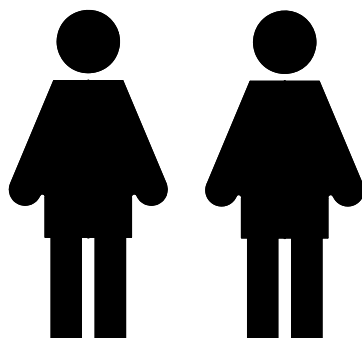
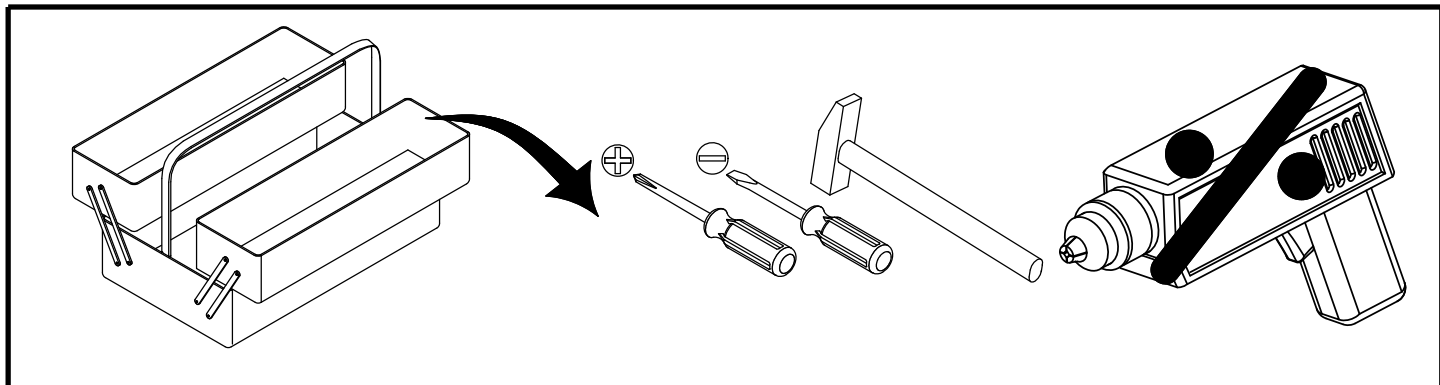
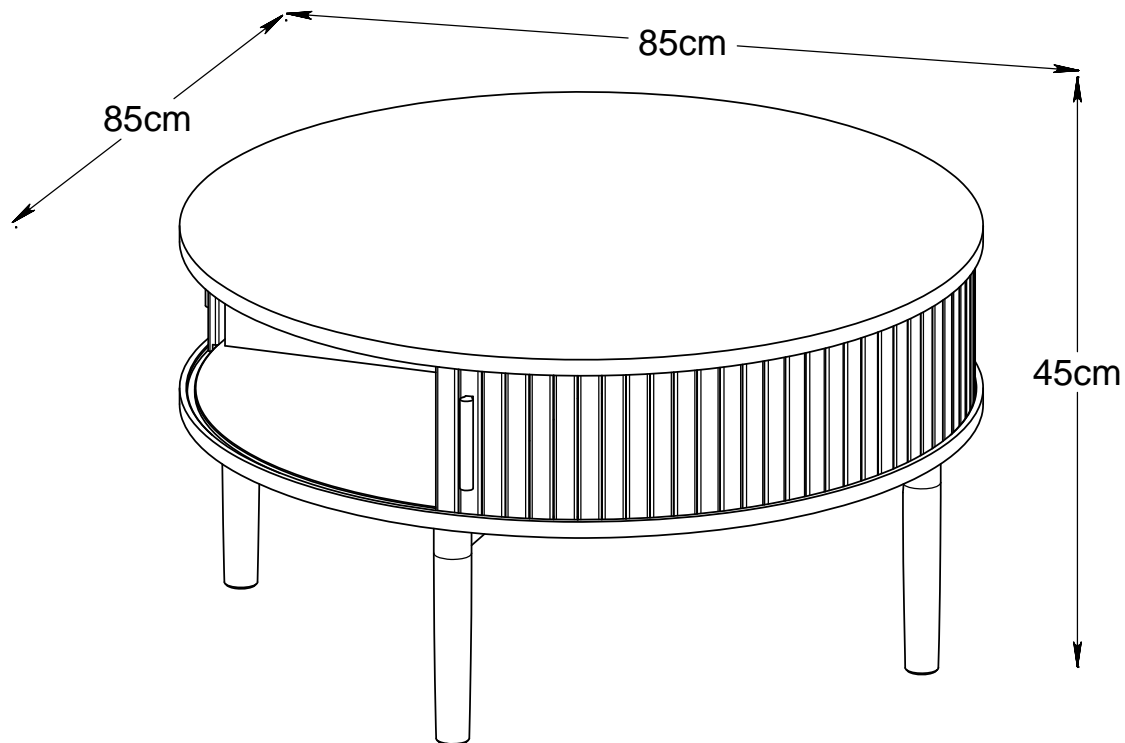

WICHTIG - FÜR SPÄTERE VERWENDUNG  
AUFBEWAHREN - SORGFÄLTIG LESEN

AVIS - Ces instructions doivent être sauvegardées  
Pour utilisation future - Les instructions doivent  
être suivies

IMPORTANTE, conservar estas instrucciones  
para futuro uso. Siga estas instrucciones atentamente

VIGTIGT - Samvejledningen skal opbevares  
i arkiv til senere brug - Skal gennemlæses nøje

NOTICE - These instructions must be saved  
for future use - Instructions must be followed

TEILCHECKLISTE  
 LISTE DE CONTROLE  
 LISTADO DE CONTROL  
 TJEKLISTE  
 CHECK LIST

## 55892560

Réf./No.	Réf./Art.	Qty./Stck./Quantité	Size / Maß / Dimension (mm)	Packed in box	✓
1	333315256	1	Ø850x18	1	
2	333316256	1	Ø850x18	1	
3	333317256	1	164x800x16	1	
4	333318256	2	164x392x16	1	
5	333319256	1	810x250x40	1	
6	333320256	1	810x250x40	1	
7	333321256	2	340x40x20	1	
8	333322256	1	1950x174x12	1	
9	333302256	2	100x17x14	1	

## 55893180

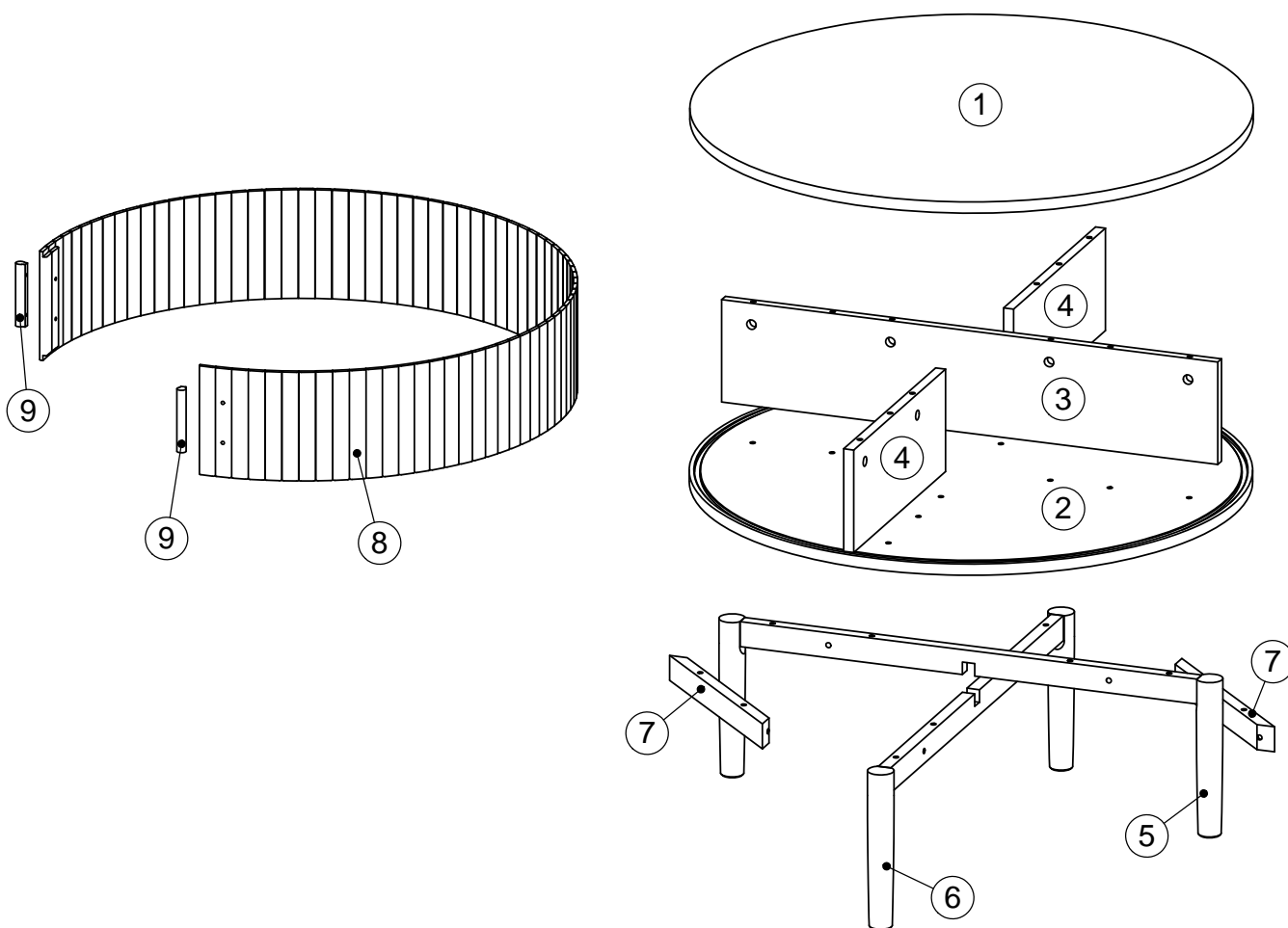

Réf./No.	Réf./Art.	Qty./Stck./Quantité	Size / Maß / Dimension (mm)	Packed in box	✓
1	333315318	1	Ø850x18	1	
2	333316318	1	Ø850x18	1	
3	333317318	1	164x800x16	1	
4	333318318	2	164x392x16	1	
5	333319318	1	810x250x40	1	
6	333320318	1	810x250x40	1	
7	333321318	2	340x40x20	1	
8	333322318	1	1950x174x12	1	
9	333302318	2	100x17x14	1	



TEILCHECKLISTE - LISTE DE CONTROLE - LISTADO DE CONTROL- TJEKLISTE - CHECK LIST

Réf./No.	Réf./Art.	Qty./Stck./Quantité	✓
A	233323	8	
B	233323	12	
C	233323	4	
D	233323	8	
E	233323	8	
F	233323	8	
K	233323	1	
N	233323	4	
P	233323	8	

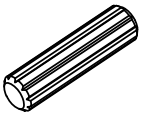
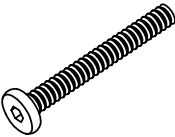
Réf./No.	Réf./Art.	Qty./Stck./Quantité	✓
Q	233323	4	

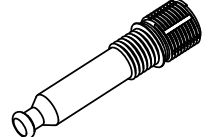
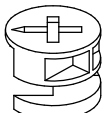
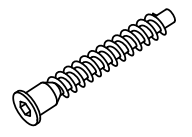
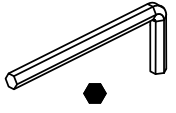
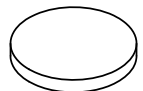
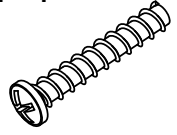
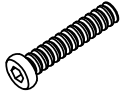
<p>8 - A</p>  <p>∅8x30mm</p>	<p>12 - B</p>  <p>M6x50mm</p>	<p>4 - C</p>  <p>∅10x16mm</p>	<p>8 - D</p>  <p>∅7x44mm</p>	<p>8 - E</p>  <p>∅15x11mm</p>	<p>8 - F</p>  <p>∅7x50mm</p>
<p>1 - K</p>  <p>4mm</p>	<p>4 - N</p>  <p>∅25x3mm</p>	<p>4 - P</p>  <p>M4x16mm</p>	<p>4 - Q</p>  <p>M6x30mm</p>		

Geehrter Kunde.  
Hier haben Sie die Möglichkeit die mitgelieferten  
Schrauben nachzumessen.

Cher client.  
Vous avez ici la possibilité de mesurer la quincaillerie fournis.

Estimado cliente.  
aquí podrá medir la tornillería adjunta.

Kære kunde.  
Her har De muligheden for at måle medsendte beslag.

Dear Customer.  
Use below ruler to measure the enclosed Hardware. (Important for  
US Customers, this must print in A4 Format for 100% accuracy)

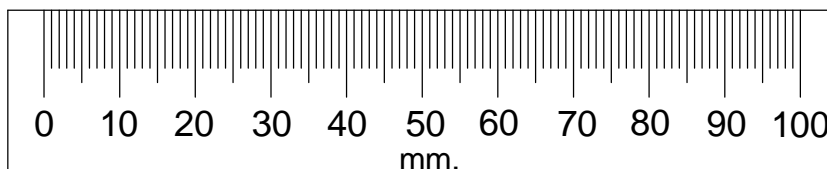

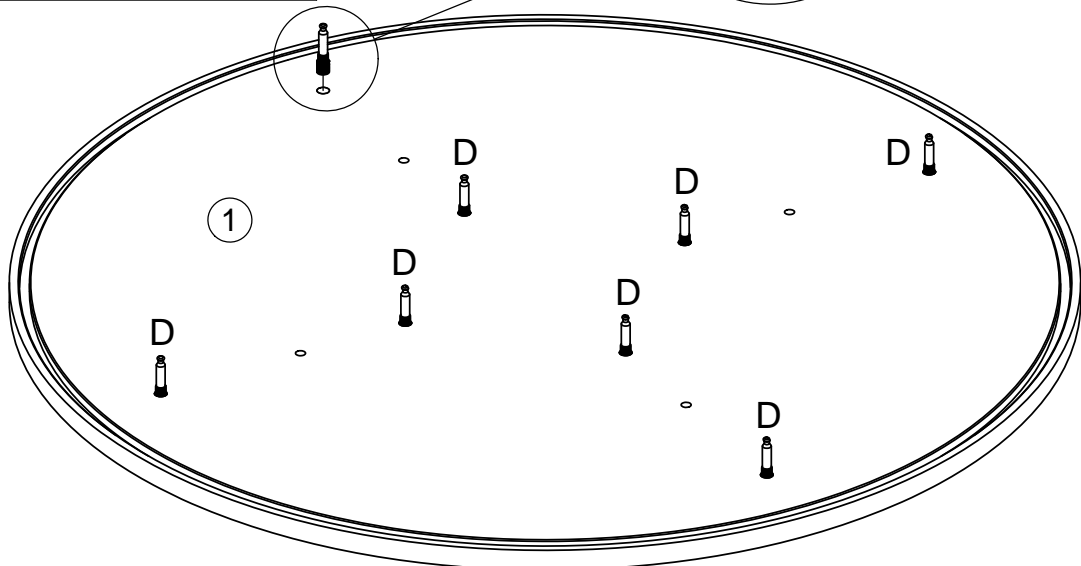
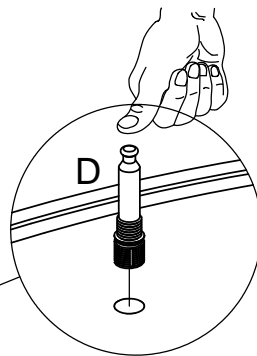
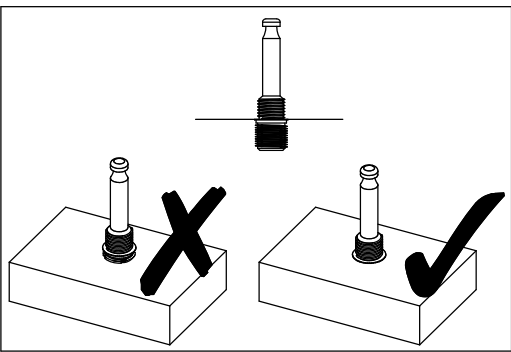
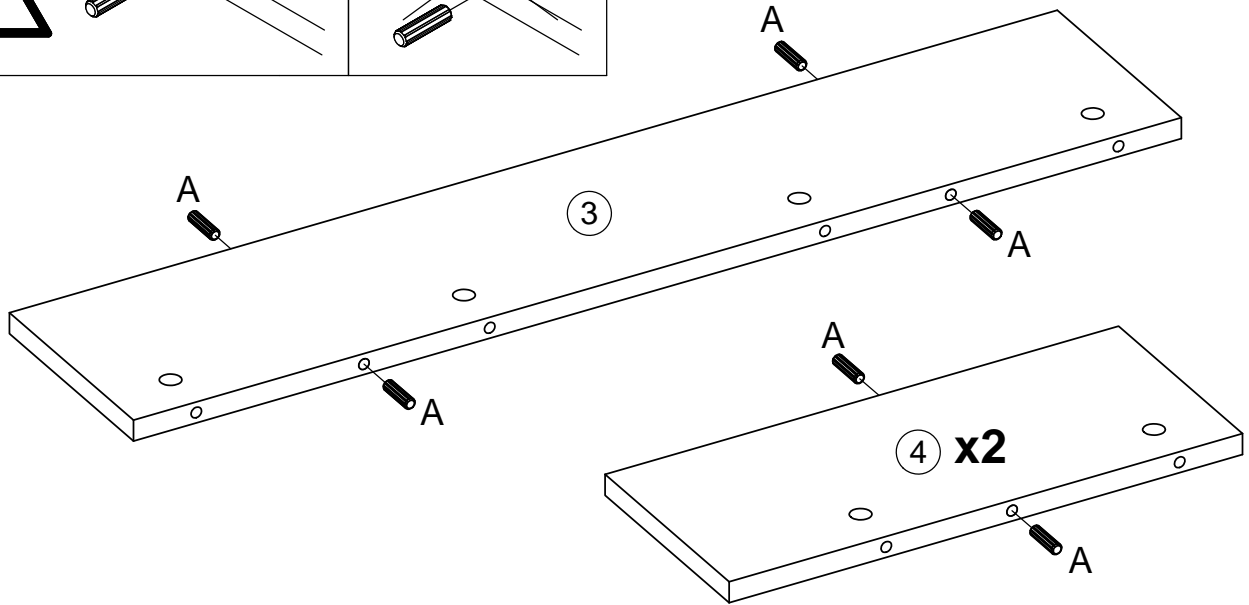
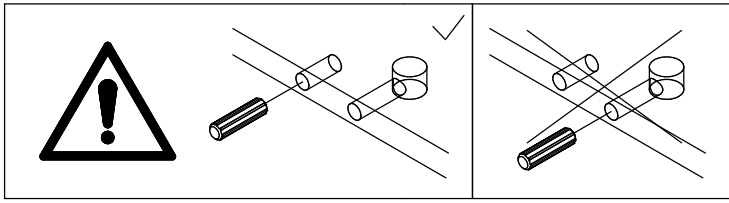

**3** E x 8 

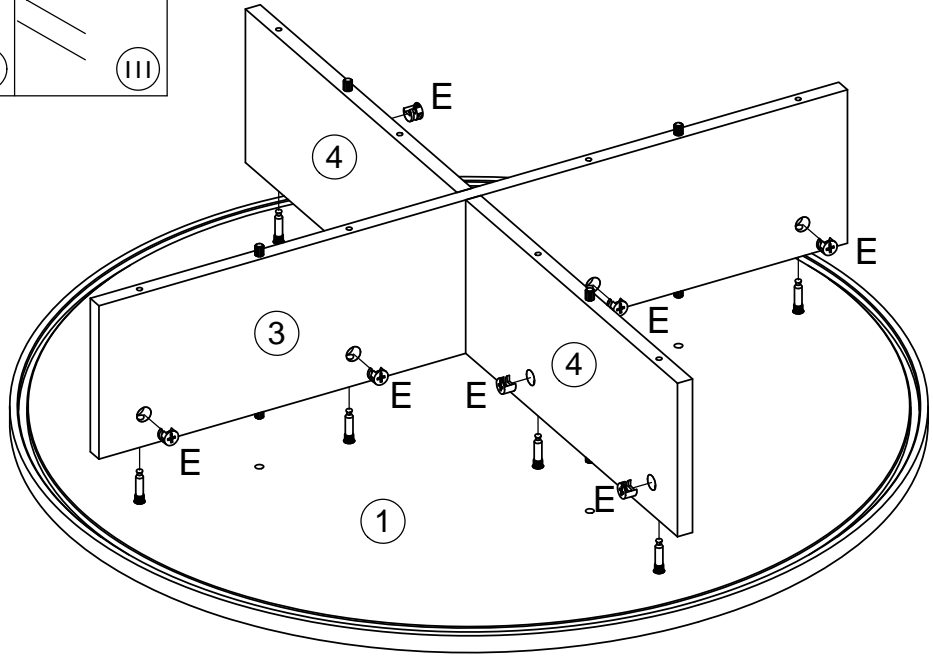
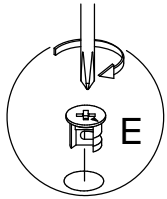
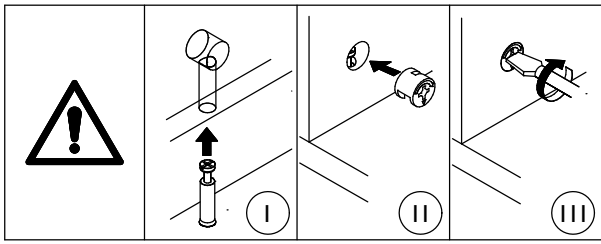

**4** P x 4 

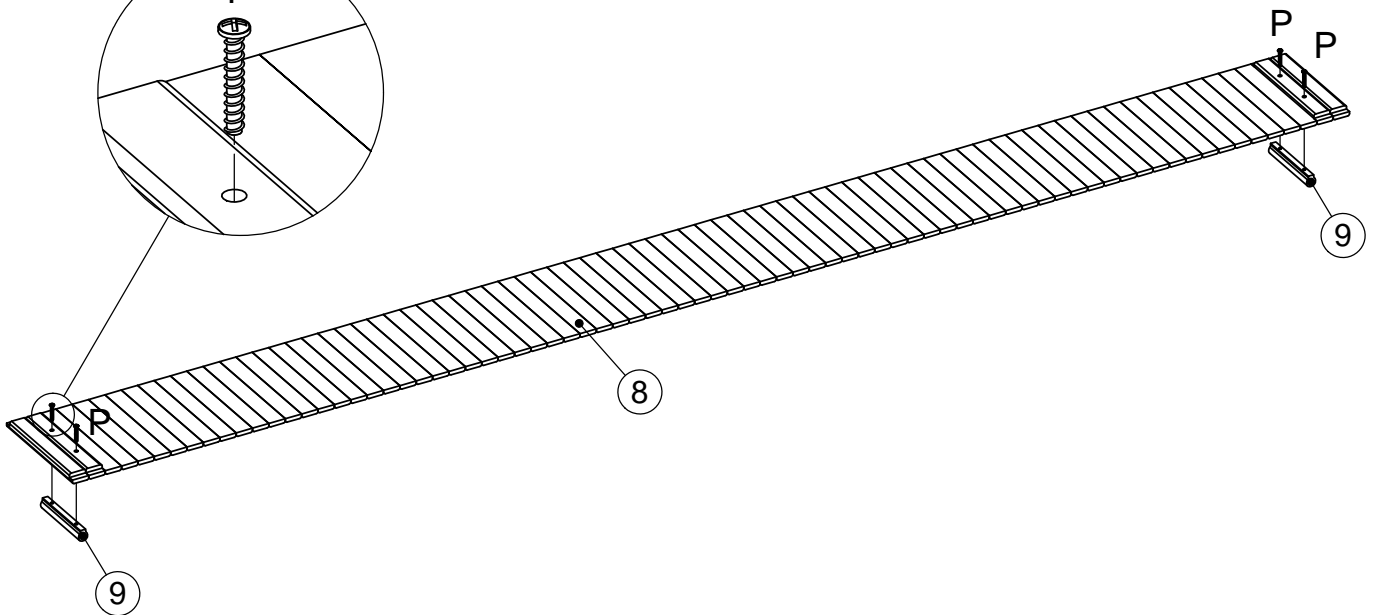
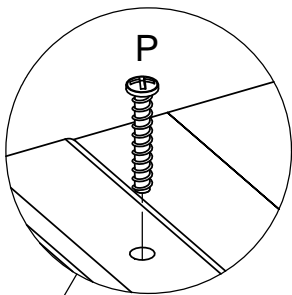

5

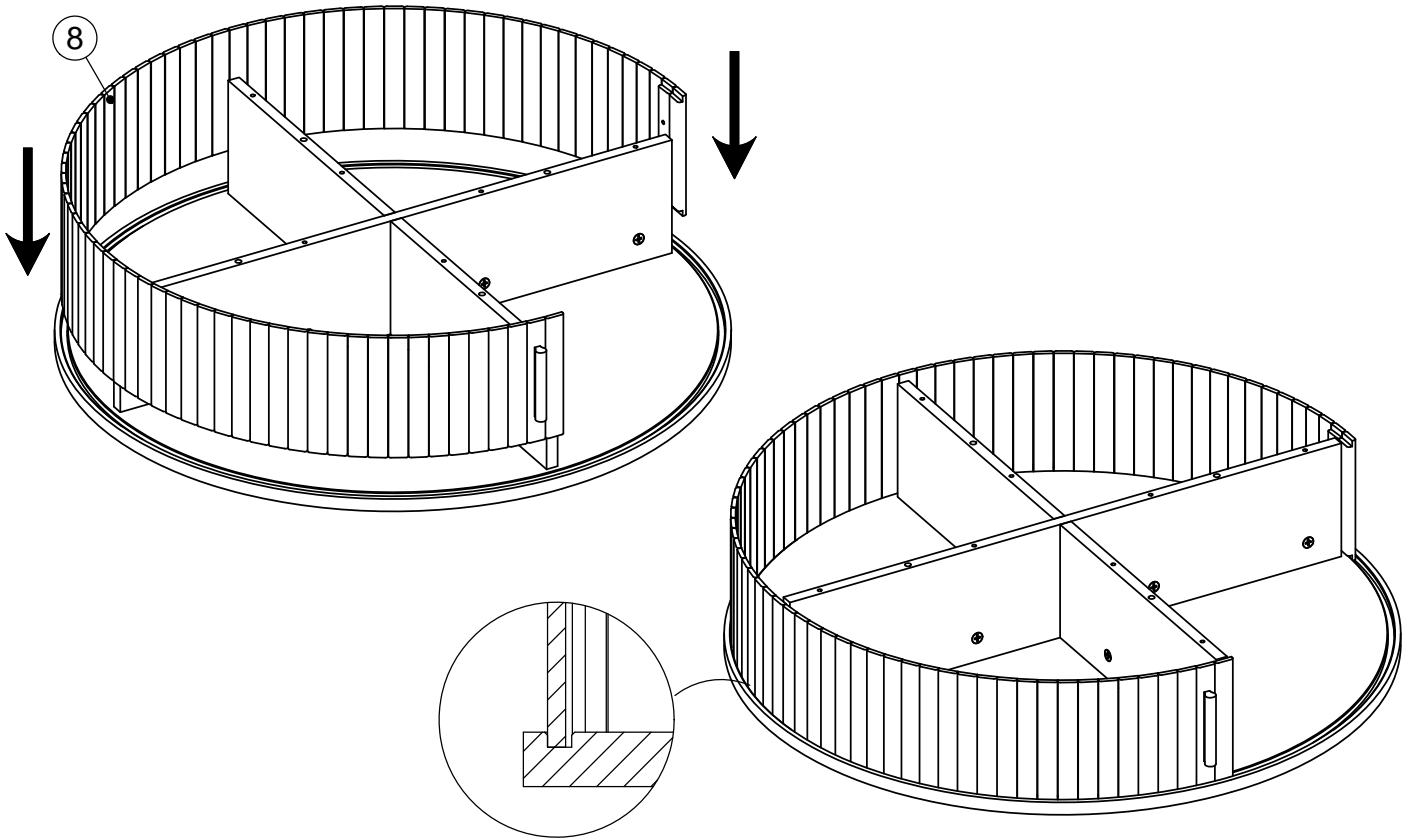

6

F x 8    K x 1

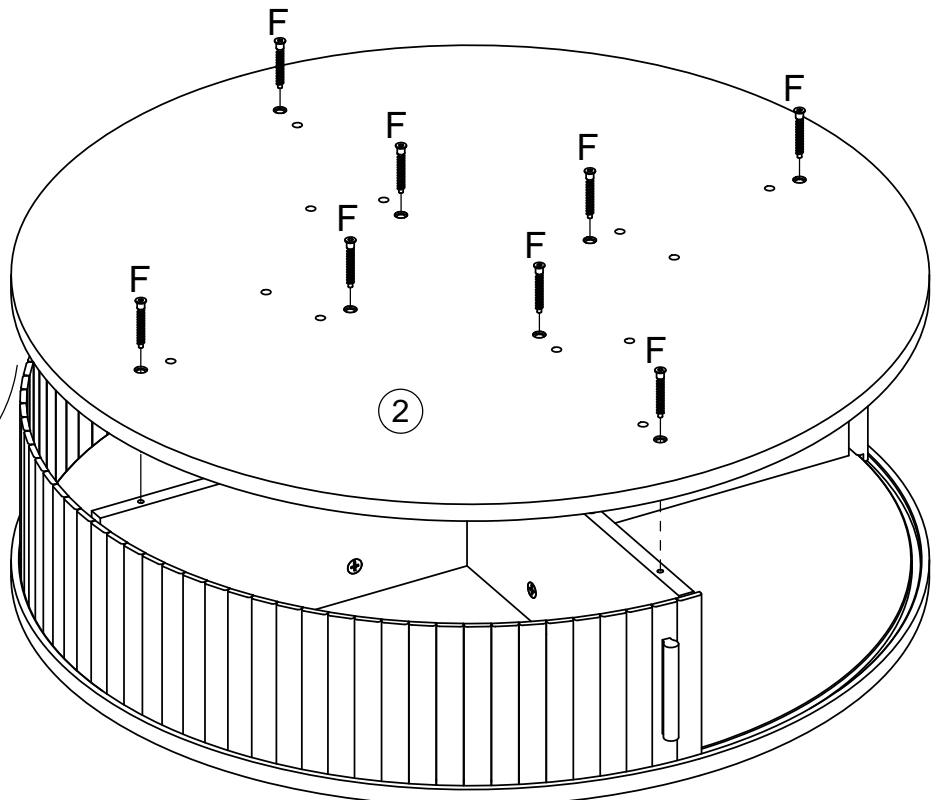
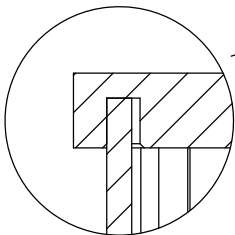
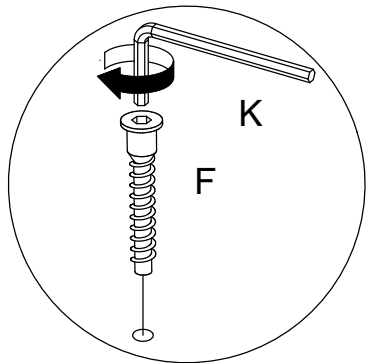
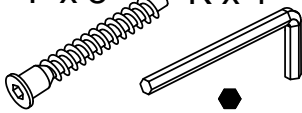

7

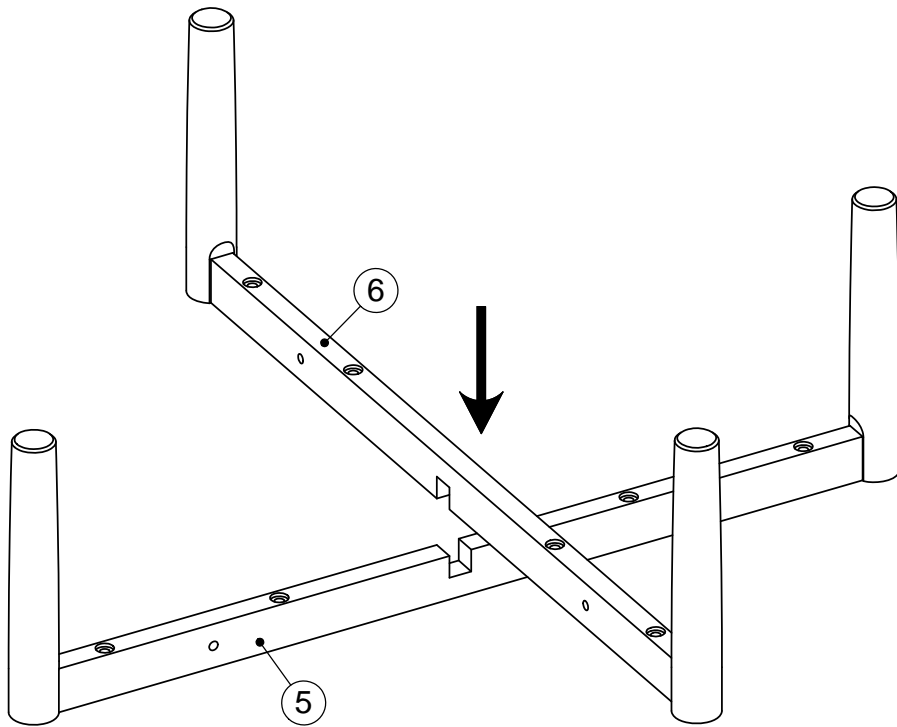

8

Q x 4    C x 4    K x 1

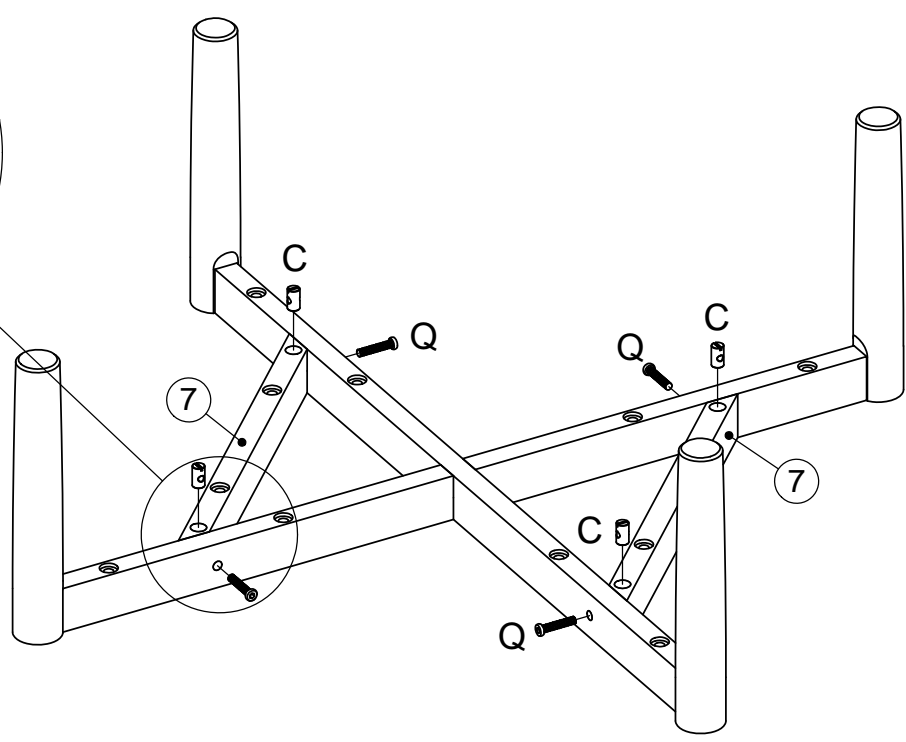
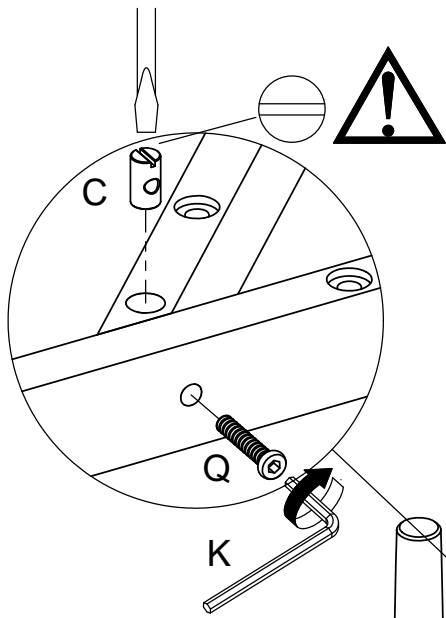

**9**     $B \times 12$      $K \times 1$

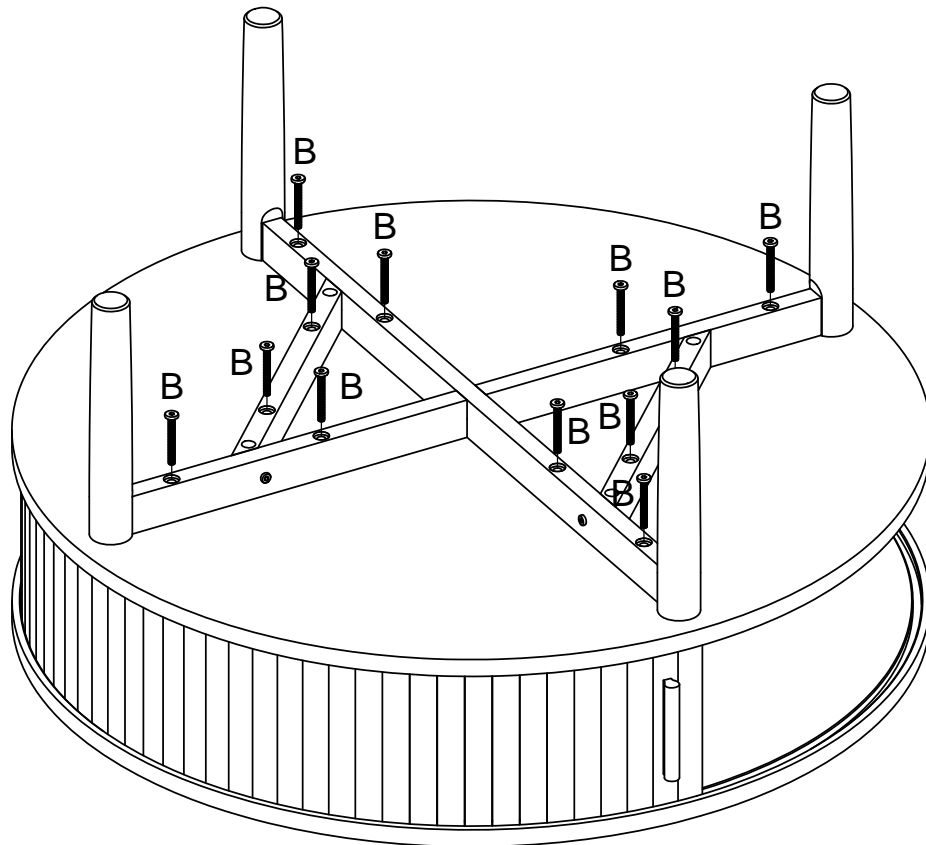
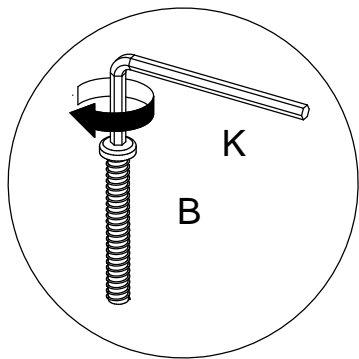

**10**     $N \times 4$

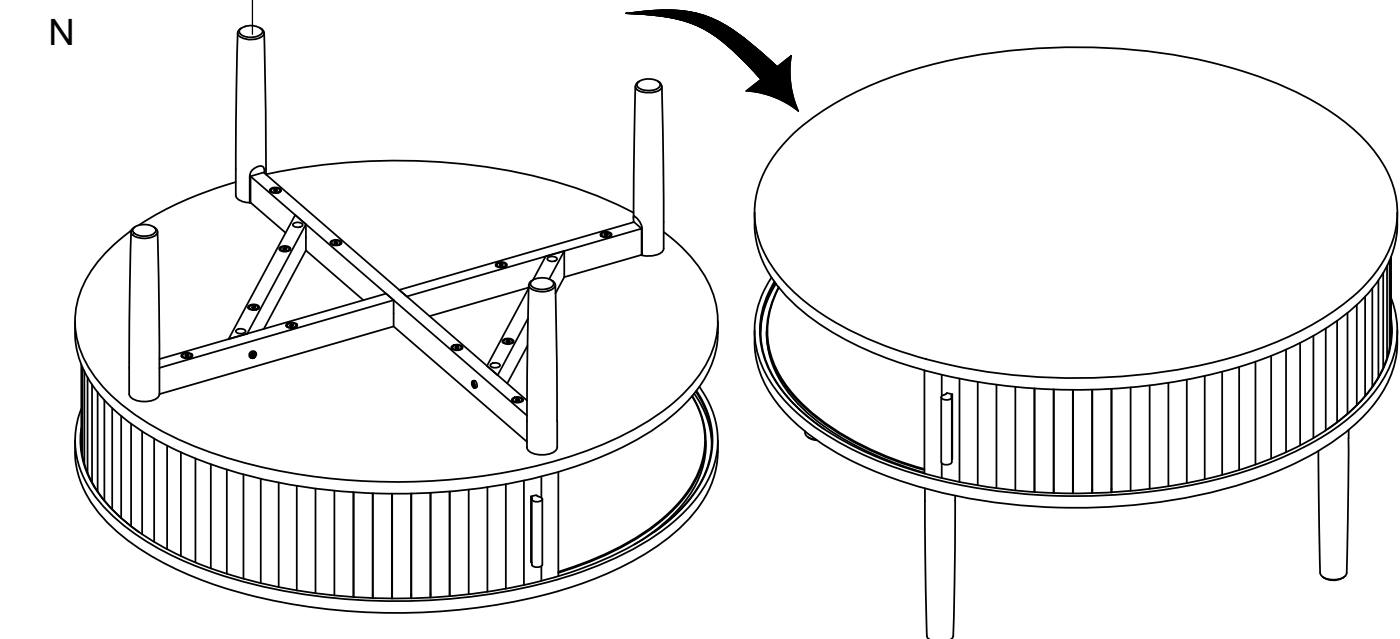
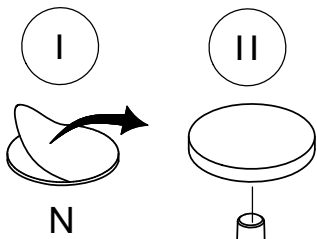

11

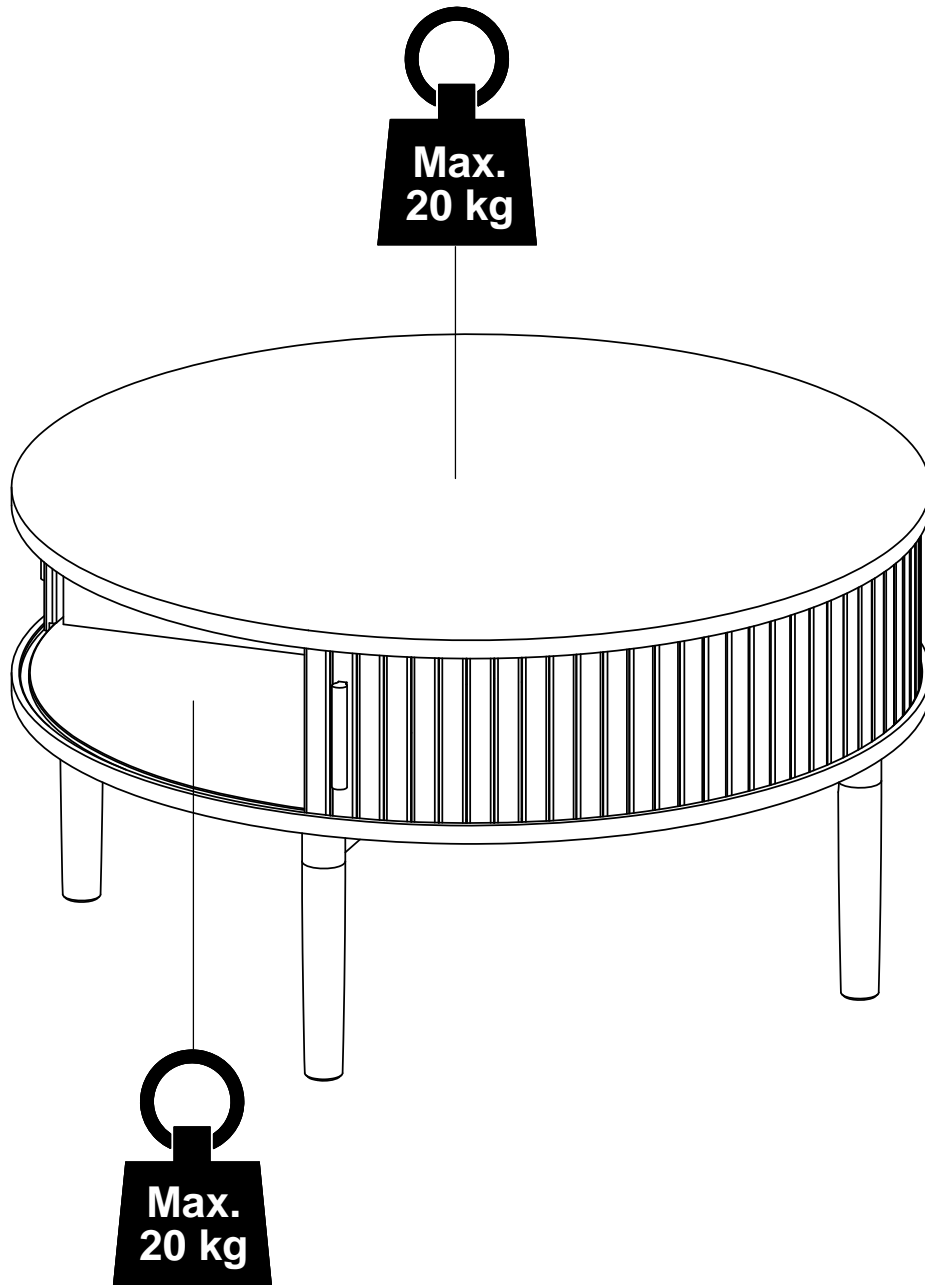



UK:

It is important that any product which is assembled using any kind of screw is re-tightened 2 weeks after assembly, and once every 3 months - in order to assure stability through-out the lifespan of the product.

DE:

Es ist wichtig, bei jedem mit Schrauben montierten Produkt diese 2 Wochen nach dem Zusammenbau sowie einmal alle 3 Monate wieder anzuziehen, um die Stabilität des Produkts über die gesamte Lebensdauer hinweg zu gewährleisten.

ES:

En el caso de los productos ensamblados, es importante volver a apretar los tornillos 2 semanas después del montaje y después cada 3 meses, para así preservar la estabilidad durante toda la vida útil del producto.

FR:

Il est important que tout produit monté à l'aide de vis soit resserré 2 semaines après son montage, puis tous les 3 mois, afin de garantir sa stabilité durant tout son cycle de vie.

DK: VIGTIGT!

Det er vigtigt, at alle produkter, der samles med alle former for skruer, efterspændes to uger efter samling samt hver tredje måned for at sikre, at produktet er stabilt i hele dets levetid.